

**UNITED STATES DISTRICT COURT
DISTRICT OF NEW JERSEY**

NANCY LUDWIG and JOSEPH SPILLANE, on
behalf of themselves and all others similarly
situated,

Plaintiffs,

v.

FCA US LLC,

Defendant.

Case No.: 24-8906

CLASS ACTION COMPLAINT

DEMAND FOR JURY TRIAL

TABLE OF CONTENTS

Page

| | | |
|-------|---|----|
| I. | INTRODUCTION | 1 |
| II. | JURISDICTION AND VENUE | 2 |
| III. | PARTIES | 3 |
| | A. Plaintiffs..... | 3 |
| | 1. Nancy Ludwig..... | 3 |
| | 2. Joseph Spillane..... | 5 |
| | B. Defendant..... | 7 |
| IV. | FACTUAL ALLEGATIONS | 7 |
| | A. The Nature of the Class Vehicle’s Power Steering System..... | 7 |
| | B. The Class Vehicles Suffer From an Unreasonable Safety Defect | 9 |
| | C. FCA’s Knowledge of the Power Steering Defect | 21 |
| | 1. NHTSA Complaints..... | 21 |
| | 2. FCA’s Inadequate Safety Recalls | 22 |
| | 3. Elevated Warranty Claims and High Service Part Demand | 22 |
| | D. FCA’s Sales and Service Agreements with its Authorized Dealers | 34 |
| | E. FCA Advertised the Class Vehicles as Safe and Reliable While Omitting the Power Steering Defect | 35 |
| | F. FCA’s Sale of Certified Pre-Owned Vehicles | 36 |
| V. | TOLLING OF STATUTES OF LIMITATIONS | 36 |
| | A. Discovery Rule..... | 36 |
| | B. Fraudulent Concealment | 37 |
| | C. Estoppel..... | 37 |
| VI. | CLASS ACTION ALLEGATIONS | 38 |
| VII. | CAUSES OF ACTION | 40 |
| | COUNT I: VIOLATIONS OF THE MAGNUSSON-MOSS WARRANTY ACT..... | 40 |
| | COUNT II: FRAUDULENT CONCEALMENT/OMISSION..... | 42 |
| | COUNT III: UNJUST ENRICHMENT..... | 44 |
| | COUNT IV: VIOLATION OF NEW JERSEY CONSUMER FRAUD ACT | 45 |
| | COUNT VII: BREACH OF IMPLIED WARRANTY OF MERCHANTABILITY | 48 |
| VIII. | PRAYER FOR RELIEF | 50 |
| IX. | DEMAND FOR JURY TRIAL | 50 |

CLASS ACTION COMPLAINT

Plaintiffs Nancy Ludwig and Joseph Spillane (“Plaintiffs”), on behalf of themselves and a class of other similarly situated individuals (collectively, “the Class”), complain of and allege the following causes of action against Defendant FCA US LLC (“FCA” or “Defendant”) as follows:

I. INTRODUCTION

1. Plaintiffs have filed this class action lawsuit on behalf of themselves, as individuals, and a class of current and former owners and lessees of the 2013-2024 Ram 1500 pickup trucks, which are designed, manufactured, and sold by FCA.¹

2. This action arises from FCA’s long-standing fraudulent concealment of a defect in the Class Vehicles, wherein the electric power steering unit (“EPS Unit”) suddenly fails without warning while the vehicle is being operated, leading to a loss of power steering assistance and creating an unreasonable safety risk for drivers attempting to maintain control of their vehicles (“Power Steering Defect”).

3. For years, FCA has actively concealed the Power Steering Defect from owners and lessees of the Class Vehicles, withholding its knowledge because once known, the Power Steering Defect would reveal their overpayment for the Class Vehicles and cause them to demand FCA to provide immediate and costly repairs, or reimbursement for such repairs.

4. Despite thousands of complaints of power steering loss in the Class Vehicles, FCA has maintained that the EPS Unit installed in each Class Vehicle is non-defective, with the narrow exception of a few hundred 2016 Ram 1500 and 2019 Ram 1500 vehicles, which FCA has claimed was caused by isolated manufacturing problems during a limited production period. For nearly a

¹ Plaintiffs reserve the right to amend or add to the vehicle models included in the definition of Class Vehicles after conducting discovery.

decade, FCA has maintained this narrative because it wishes to avoid its responsibility to cover the cost of remediating the Power Steering Defect. As a result, FCA's customers (including Plaintiffs) have been left with expensive bills to repair and/or replace their vehicles' EPS Units. A repair typically costs approximately \$3,000 – \$4,000.

5. In August 2023, the National Highway Transportation Safety Administration (“NHTSA”) took notice of the substantial discrepancy between the limited scope of FCA's recalls for power steering loss in the 2016 Ram 1500 and the increasing number of consumer complaints about the problem in 2013-2016 Ram 1500 vehicles. As a result, NHTSA's Office of Defect Investigation (“ODI”) opened an investigation into the loss of power steering in the 2013-2016 Ram 1500 vehicles “to determine if the scope of the recall . . . is correct or if another defect might exist that causes the alleged steering concerns.” In commencing the investigation, NHTSA noted that it had received nearly 400 reports from consumers “alleging an intermittent or complete loss of power steering assistance in certain 2013-2016 Ram 1500.”

6. While NHTSA's investigation is ongoing, millions of owners and lessees of the Class Vehicles remain ignorant of the Power Steering Defect, placing them at risk of serious injury by their continued use of their vehicles without adequate inspection or repairs.

7. Accordingly, Plaintiffs bring this action to redress FCA's violations of the consumer protection statutes and seek recovery for FCA's breaches of implied warranty, and its fraudulent omissions and concealment of the Power Steering Defect.

II. JURISDICTION AND VENUE

8. This Court has subject matter jurisdiction of this action pursuant to 28 U.S.C. § 1332 of the Class Action Fairness Act of 2005 because: (i) there are 100 or more Class members, (ii) there is an aggregate amount in controversy exceeding \$5,000,000, exclusive of interest and costs, and (iii) there is minimal diversity because at least one plaintiff and one defendant are

citizens of different States. This court has supplemental jurisdiction over the state law claims pursuant to 28 U.S.C. § 1367.

9. This Court has specific personal jurisdiction over FCA because it is registered to conduct business in New Jersey, has purposefully availed itself of the benefits and protections of New Jersey by conducting continuously and systematically conducting substantial business in this judicial district, directing advertising and marketing materials to districts within Illinois, and intentionally and purposefully placing Class Vehicles into the stream of commerce within the districts of New Jersey and throughout the United States with the expectation and intent that they would be purchased by consumers.

10. Venue is proper in this judicial district pursuant to 28 U.S.C. §1391 because FCA transacts business in this District, is subject to personal jurisdiction in this District, and therefore is deemed to be citizens of this district. Additionally, there are one or more authorized Ford dealers within this District and FCA has advertised in this District and have received substantial revenue and profits from their sales and/or leasing of Class Vehicles in this district; therefore, a substantial part of the events and/or omissions giving rise to the claims occurred, in part, within this District.

III. PARTIES

A. Plaintiffs

1. Nancy Ludwig

11. Plaintiff Nancy Ludwig is a citizen and resident of Bridgewater, New Jersey.

12. On August 15, 2020, Ludwig purchased a pre-owned 2016 Ram 1500 (“the vehicle” for purposes of this section) from Flemington Chrysler Dodge Jeep Ram (“Flemington Chrysler”), an authorized FCA dealership in Flemington, New Jersey

13. Ludwig uses the vehicle for personal, family and/or household uses.

14. Passenger safety and reliability were important factors in Ludwig's decision to purchase the vehicle.

15. Prior to purchasing the vehicle, Ludwig was exposed to and viewed various advertisements and promotional materials that touted the quality, reliability, safety, and durability of the Class Vehicles, and the Ram brand generally. She relied on these advertisements when deciding to purchase the vehicle. The advertisements did not state the Class Vehicles suffered from any defects.

16. Prior to purchasing the vehicle, Ludwig spoke with one or more sales representatives at Flemington Chrysler regarding the various features, benefits, and attributes of the vehicle and relied on those when making her purchase.

17. At the time of Ludwig's purchase, FCA knew that the EPS Units it installed in the Class Vehicles were defective, but the FCA sales representative did not disclose the Power Steering Defect to Ludwig when discussing the features, components, and performance of the vehicle prior to purchase. In reliance on these material omissions and misrepresentations, Ludwig purchased – then operated the vehicle on the reasonable, but incorrect, belief that the vehicle was free of defects.

18. Had Ludwig been informed of the Power Steering Defect prior to or at the time of purchase, she would not have purchased the vehicle or else would have paid significantly less for the vehicle.

19. On January 1, 2024, Ludwig's domestic partner and the vehicle's co-owner, Jason Yingst, was exiting a McDonald's drive-through lane in the vehicle when he experienced power steering failure – the vehicle's steering wheel immediately became stiff and difficult to turn, nearly causing him to crash into two pedestrians.

20. As a result of the power steering failure, Ludwig had the vehicle towed to a mechanic at a local Nissan dealership to diagnose the problem. The mechanic informed her that the vehicle's electric power steering unit had failed, requiring replacement of the entire steering rack and pinion. The mechanic also informed her that FCA had issued a recall for failure of the EPS Unit in certain 2015-2016 Ram 1500s.

21. With that information, Ludwig contacted Flemington Chrysler to inquire about a potential defect and recall for the electric power steering unit on her vehicle. Flemington denied any knowledge of the problem and informed Ludwig that their truck was not covered by any recall relating to electric power steering failure.

22. As a result, Ludwig escalated her complaints directly to FCA's Customer Care department, who opened a customer claim, but ultimately denied her request to cover the cost required to replace the vehicle's electric power steering rack and pinion.

23. Consequently, Ludwig had to pay \$4,484.59 out-of-pocket to have Fullerton Chrysler Jeep Dodge Ram, a dealership (and authorized FCA service technician) in Somerville, New Jersey, replace the electric power steering rack and pinion on the vehicle.

2. Joseph Spillane

24. Plaintiff Joseph Spillane is a citizen and resident of Toms River, New Jersey.

25. On January 1, 2014, Spillane purchased a new 2013 Ram 1500 ("the vehicle" for purposes of this section) from Route 46 Chrysler Jeep Dodge ("Route 46 Chrysler"), an authorized FCA dealership in Little Falls, New Jersey

26. Spillane uses the vehicle for personal, family and/or household uses.

27. Passenger safety and reliability were important factors in Spillane's decision to purchase the vehicle.

28. Prior to purchasing the vehicle, Spillane was exposed to and viewed various advertisements and promotional materials that touted the quality, reliability, safety, and durability of the Class Vehicles, and the Ram brand generally. He relied on these advertisements when deciding to purchase the vehicle. The advertisements did not state the Class Vehicles suffered from any defects.

29. Prior to purchasing the vehicle, Spillane spoke with one or more sales representatives at Route 46 Chrysler regarding the various features, benefits, and attributes of the vehicle and relied on those when making his purchase.

30. At the time of Spillane's purchase, FCA knew that the EPS Units it installed in the Class Vehicles were defective, but the FCA sales representative did not disclose the Power Steering Defect to Spillane when discussing the features, components, and performance of the vehicle prior to purchase. In reliance on these material omissions and misrepresentations, Spillane purchased – then operated the vehicle on the reasonable, but incorrect, belief that the vehicle was free of defects.

31. Had Spillane been informed of the Power Steering Defect prior to or at the time of purchase, he would not have purchased the vehicle or else would have paid significantly less for the vehicle.

32. In late July or early August 2024, Spillane was driving the vehicle home from a trip to Pennsylvania. As he pulled into the driveway of his home, the power steering in the vehicle failed and an alert on the speedometer display appeared, which stated: “service power steering.”

33. Shortly thereafter, Spillane contacted FCA's customer service hotline to complain about the failure and inquire about the availability of a fix under warranty or any potential recalls. FCA declined to provide any coverage for the failure, and instead told Spillane to take the vehicle

to his local FCA dealership for diagnosis and to determine whether the causal part was subject to a recall.

34. As a result of the power steering failure, Spillane had the vehicle towed to Route 46 to diagnose the problem. At that time, Route 46 Chrysler informed him that the vehicle's electric power steering unit had failed, requiring replacement of the entire steering rack and pinion. At that time, Spillane was informed by Route 46 Chrysler that the estimated cost of repair would be \$2,800 and that rack and pinion for his vehicle was currently unavailable due to a national backorder.

35. As result, Spillane has been left with a completely inoperable vehicle for the foreseeable future and anticipates paying at least \$2,800 out-of-pocket to have Route 46 Chrysler replace the electric power steering rack and pinion on the vehicle once the part becomes unavailable.

B. Defendant

36. Defendant FCA US LLC ("FCA") is a Michigan limited liability company, with its principal office located in Auburn Hills, Michigan. FCA advertises, distributes, warrants, sells, and leases various vehicles under several prominent brand names, including Chrysler, Jeep, and Dodge, in this District and throughout the United States through a network of authorized retail dealers. FCA manufactured and designed Class Vehicles.

IV. FACTUAL ALLEGATIONS

A. The Nature of the Class Vehicle's Power Steering System

37. Power steering has long been a staple of modern automobiles, introduced for the first time (coincidentally) in the 1951 Chrysler Imperial. Power steering allows a driver to steer a heavy vehicle with far less effort and greater comfort than a vehicle without. In particular, power

steering vastly improves “steering response” or the speed at which the automobile changes direction in response to the driver turning the steering wheel.

38. Electric power steering (“EPS”) is a modern power steering system that replaces hydraulic components with electric motors and sensors. As illustrated in *Figure 1* below, an electric motor mounted on either the steering column or steering gear (typically rack-and-pinion) applies torque to the steering column, assisting the driver to turn the steering wheel. Sensors detect the steering wheel’s position and any input from the driver – hauling on the wheel to change the vehicle’s direction. A control module applies assistive torque via the electric motor. The EPS module works by calculating the amount of steering assist needed, based on several factors and sensor inputs sent from the steering angle and torque sensors. Once the EPS module processes this data, it responds by controlling the current being applied to the EPS motor and moving the steering gear to the desired position.

Figure 1

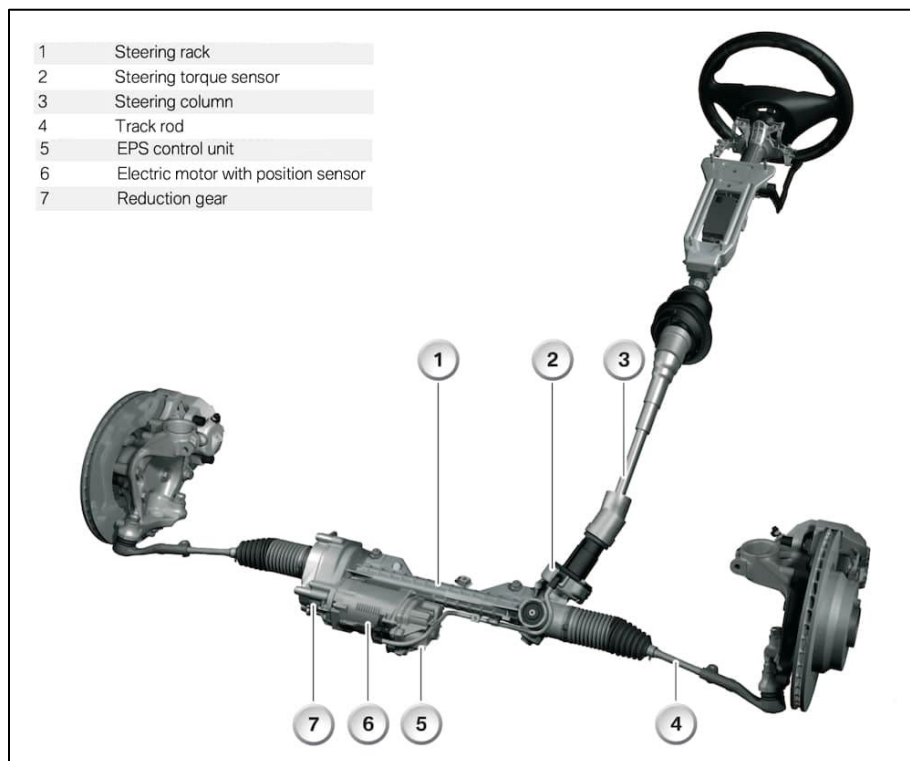

39. Each Class Vehicle is assembled, manufactured, and sold with an electric power steering (“EPS”) rack and pinion system that shares the same or common design.

40. As illustrated in *Figure 2*, the electric steering rack and pinion is equipped with an EPS Unit, which houses the EPS motor and EPS control module.

Because the EPS Unit is affixed to the steering rack and pinion, Class Vehicle owners must replace the entire steering rack and pinion when it fails.

Figure 2

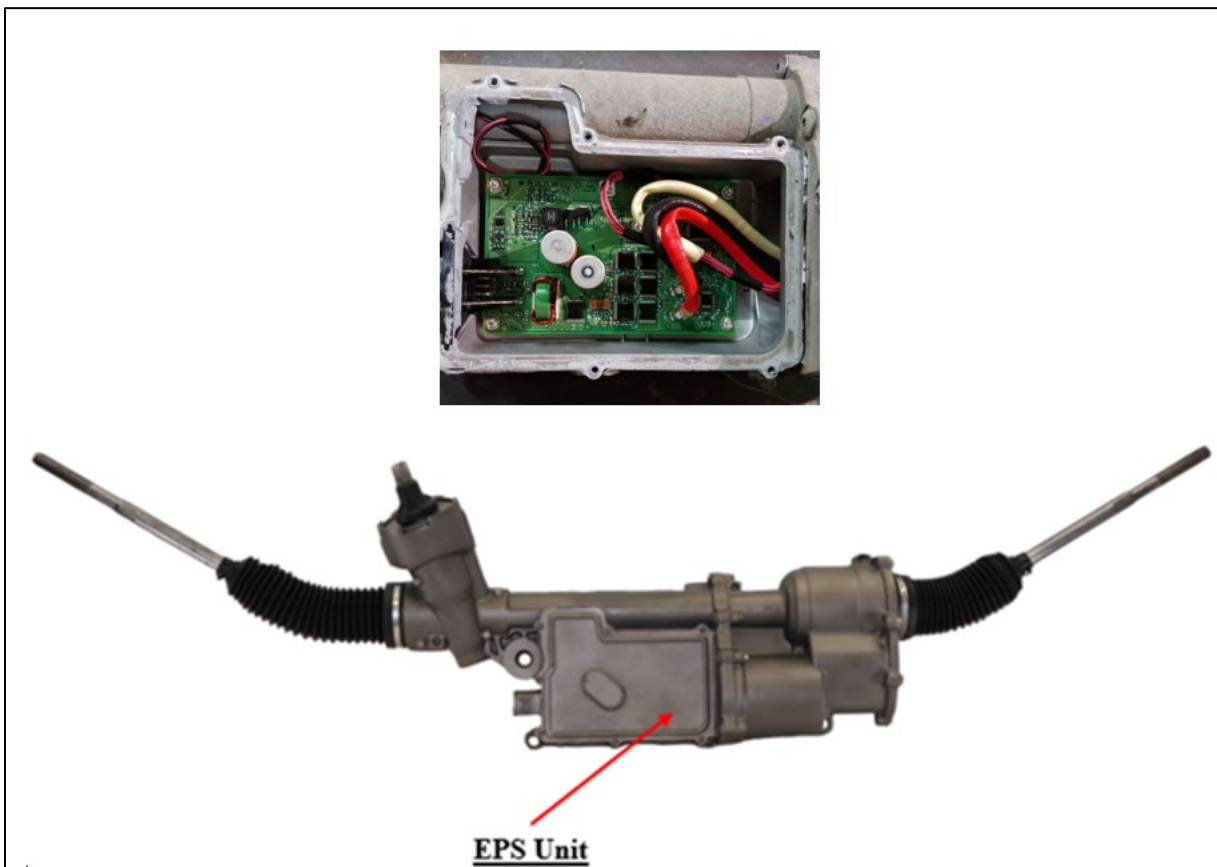

B. The Class Vehicles Suffer From an Unreasonable Safety Defect

41. The Class Vehicles contain the Power Steering Defect, a latent uniform defect that manifests in a sudden failure of the EPS Unit while the vehicle is being operated under normal driving conditions. When the Power Steering Defect manifests, the vehicle’s steering wheel

immediately stiffens and becomes difficult to turn, surprising the driver and requiring increased steering efforts to maintain control of the vehicle. The combination of these changes, along with the surprise to the driver, creates an unreasonable safety risk as it increases the chances or likelihood of crash events from drivers losing control of the Class Vehicles.

42. The Power Steering Defect exists at the time of purchase; however, its hazardous effects—*i.e.*, the loss of power steering—and symptoms remain latent until many purchasers are outside their warranty periods.

43. This publicly available database contains all motor vehicle-related consumer complaints submitted to NHTSA since January 2000. Consumers submit what is called a “Vehicle Owner Questionnaire” (hereinafter, “NHTSA Complaint”) in which they asked to provide information that includes, the make, model, and model year of the vehicle, the approximate incident date, the mileage at which the incident occurred, whether the incident involved a crash or a fire, whether any persons were injured or killed in the incident, the speed of the vehicle at the time of the incident, and a description of the incident along with a description of the vehicle components they believe were involved in the incident. The majority of consumer complaints are submitted online at www.nhtsa.gov, where consumers can input this information directly into the database through their computers. They can also submit complaints by telephone through the Auto Safety Hotline, through submitting a paper Vehicle Owner Questionnaire form, and by mailing consumer letters to NHTSA. This information is then entered into NHTSA’s ARTEMIS database where it can be searched and reviewed by the general public and vehicle manufacturers alike, by make, model, model year, and component. NHTSA promotes this database as a valuable consumer information tool.

44. To date, drivers of the Class Vehicles have submitted at least 32 NHTSA Complaints involving crash incidents resulting from the Power Steering Defect. As evidenced by these NHTSA Complaints, the Power Steering Defect presents an unreasonable safety risk to drivers and occupants of the Class Vehicles:

August 29, 2016 NHTSA ID NUMBER: 10899221

Components: STEERING

NHTSA ID Number: 10899221

Incident Date August 23, 2016

Consumer Location HUDDLESTON, VA

Vehicle Identification Number 3C6JR6DT6EG*****

Summary of Complaint

CRASHYes

FIRENo

INJURIES0

DEATHS0

TL* THE CONTACT OWNS A 2014 RAM 1500. WHILE THE VEHICLE WAS STOPPED AT A MEDIAN AND PROCEEDING TO MAKE A LEFT TURN, THE STEERING WHEEL SEIZED. THE VEHICLE DROVE INTO A DITCH. THE CONTACT STATED THAT THE STEERING WHEEL INDICATOR ILLUMINATED AFTER THE FAILURE OCCURRED. NO INJURIES WERE SUSTAINED AND A POLICE REPORT WAS NOT FILED. THE VEHICLE WAS TOWED TO A DEALER WHERE IT WAS DIAGNOSED THAT THE RACK AND PINION STEERING MODULE FAILED AND NEEDED TO BE REPLACED. THE VEHICLE WAS NOT REPAIRED. THE MANUFACTURER WAS NOTIFIED OF THE FAILURE. THE FAILURE MILEAGE WAS APPROXIMATELY 40,000.

1 Affected Product

Vehicle

| MAKE | MODEL | YEAR |
|------|-------|------|
| RAM | 1500 | 2014 |

August 17, 2018 NHTSA ID NUMBER: 11120753

Components: STEERING, SERVICE BRAKES

NHTSA ID Number: 11120753

Incident Date August 15, 2018

Consumer Location PHILADELPHIA, PA

Vehicle Identification Number 3C6RR7LG1JG*****

Summary of Complaint

CRASHYes

FIRENo
INJURIES1
DEATHS0

I WAS DRIVING ABOUT 35-45 MPH WAS ATTEMPTING TO MOVE INTO THE RIGHT LANE AND I FELT MY STEERING WHEEL LOCK UP. IT WOULDN'T LET ME TURN MY WHEEL. SO THEN AS I ATTEMPTED TO SLAM ON MY BRAKES SO I DID T HIT A TREE THE BRAKES WENT TO THE FLOOR AND I SMASHED INTO THE TREE AND THE. I TO THE WOODS. I WAS TAKEN TO THE HOSPITAL 911. THE HOLE FRONT OF THE TRUCK IS DESTROYED.

1 Affected Product

Vehicle

| MAKE | MODEL | YEAR |
|------|-------|------|
| RAM | 1500 | 2018 |

January 30, 2019 NHTSA ID NUMBER: 11173038

Components: STEERING, ELECTRICAL SYSTEM

NHTSA ID Number: 11173038

Incident Date January 30, 2019

Consumer Location CIRCLE PINES, MN

Vehicle Identification Number 1C6RR7LG4ES*****

Summary of Complaint

CRASHYes

FIRENo

INJURIES0

DEATHS0

DURING COLD WEATHER IN MINNESOTA, THE ELECTRONIC POWER STEERING FAILED TO RESPOND CAUSING MY TRUCK TO GO INTO THE DITCH.

1 Affected Product

Vehicle

| MAKE | MODEL | YEAR |
|------|-------|------|
| RAM | 1500 | 2014 |

July 9, 2019 NHTSA ID NUMBER: 11230354

Components: STEERING

NHTSA ID Number: 11230354

Incident Date March 31, 2019

Consumer Location ESTILL, SC

Vehicle Identification Number 1C6RR6GT4FS*****

Summary of Complaint

CRASHYes

FIRENo

INJURIES0

DEATHS0

TL* THE CONTACT OWNS A 2015 RAM 1500. WHILE DRIVING 40 MPH, THE POWER STEERING MALFUNCTIONED. AS A RESULT, THE VEHICLE VEERED OFF THE ROAD AND CRASHED INTO A SMALL DITCH. THERE WERE NO INJURIES AND A POLICE REPORT WAS NOT FILED. THE VEHICLE WOULD NOT RESTART AND WAS TOWED TO PEACOCK CHRYSLER JEEP DODGE RAM FIAT (265 DRIVERS WAY A, HARDEEVILLE, SC 29927, (843) 208-1200). THE DEALER STATED THAT AN ELECTRICAL FAILURE PREVENTED THE VEHICLE FROM RESTARTING. ALSO, THE TIE ROD WAS FRACTURED AND REPAIRED BY THE CONTACT. THE DEALER QUOTED A REPAIR COST OF \$2,500 FOR THE POWER STEERING MODULATOR. THE MANUFACTURER WAS NOT CONTACTED. THE FAILURE MILEAGE WAS 120,000.

1 Affected Product

Vehicle

| MAKE | MODEL | YEAR |
|------|-------|------|
| RAM | 1500 | 2015 |

September 18, 2019 NHTSA ID NUMBER: 11256354

Components: STEERING

NHTSA ID Number: 11256354

Incident Date August 8, 2019

Consumer Location YORKTOWN, VA

Vehicle Identification Number 1C6RR7NT7FS*****

Summary of Complaint

CRASHYes

FIRENo

INJURIES0

DEATHS0

ELECTRIC POWER STEERING GRADUALLY FAILED INCIDENT TO A STRIKE ON A CONCRETE VERTICAL POLE WHILE IN A TURN APPROX 10MPH IN PARKING LOT. ALIGNMENT WAS SIGNIFICANTLY OFF. ALIGNED, BUT THE STEERING STILL CAUGHT/ FRICTION DURING TURNS, STEERING WOULD NO LONGER SCENTER UP. TOOK TO 3RD PARTY, THEY WERE UNABLE TO DIAGNOSE. BARELY USED VEHICLE, AND AFTER PARKING AND POWER OFFF, AT NEXT START THE ELECTRIC POWER STEERING TOTALLY FAILED, NEEDED TO APPLY 40-50 LBS OF FORCE ON STEERING WHEEL TO GET IT TO DO LIMITED TURNING, AND IT WOULD

FREEZE IN THE NEW POSITION. UNDRIVEABLE, PAID TO TOW TO DEALER WHO SAID IT WAS NOT DUE TO STRIKING THE BOLLARD, BUT THEY DID NOT UNDERSTAND IT STARTED RIGHT THEN AFTER STRIKING THE BOLLARD, AND THAT IT BECAME WORSE OVER THE NEXT 2 WEEKS WITH VERY LITTLE USE THEN TOTALLY FAILED. THERE IS A RECALL, BUT NOT MY VIN.

1 Affected Product

Vehicle

| MAKE | MODEL | YEAR |
|------|-------|------|
| RAM | 1500 | 2015 |

November 19, 2019 NHTSA ID NUMBER: 11281033

Components: STEERING

NHTSA ID Number: 11281033

Incident Date November 15, 2019

Consumer Location WHITE LAKE, MI

Vehicle Identification Number 1C6RR7MT3DS*****

Summary of Complaint

CRASHYes

FIRENo

INJURIES0

DEATHS0

WHILE DRIVING DOWN THE ROAD THE ELECTRONIC STEERING WENT OUT WHILE I WAS IN A TURN I COULD NOT STEER THE VEHICLE AND THIS CAUSED ME TO CROSS INTO ONCOMING TRAFFIC AND SLIDE OFF THE ROAD BEFORE I COULD STOP. AFTER 30 MIN OF TRYING TO RESTART THE VEHICLE THE MESSAGE TO SERVICE THE EPS SYSTEM WAS GONE AND I WAS ABLE TO DRIVE IT TO THE DEALERSHIP AS I WAS PULLING INTO THE DEALER IT HAPPENED AGAIN AND ALMOST HIT NEW VEHICLES IN THE LOT. THE TECHNICIAN SCANNED THE VEHICLE AND REPORTED THAT FCA WAS OR IS ISSUING A VB9 RECALL TO FIX THIS PROBLEM, THEY WILL NOT AUTHORIZE MY VEHICLE TO BE FIXED AND NO ONE HAS CALLED ME SINCE I GOT A CASE NUMBER ON FRIDAY THE CASE NUMBER IS 68148835

1 Affected Product

Vehicle

| MAKE | MODEL | YEAR |
|------|-------|------|
| RAM | 1500 | 2013 |

December 30, 2019 NHTSA ID NUMBER: 11292088

Components: STEERING

NHTSA ID Number: 11292088

Incident Date December 29, 2019

Consumer Location AMBOY, IL

Vehicle Identification Number 1C6RR7PTXFS*****

Summary of Complaint

CRASHYes

FIRENo

INJURIES0

DEATHS0

DRIVING AT 55 MPH AND MAKING A SWEEPING RIGHT HAND TURN THE VEHICLE LOCKED THE STEERING WHEEL AND CAUSED THE VEHICLE TO ENTER THE DITCH. WHEN TOWED TO THE DEALER THEY FOUND A FAILED ELECTRIC POWER STEERING GEAR. THERE IS A RECALL FROM RAM REGARDING EPS SYSTEM FAILURE ,BUT THIS UNIT WAS NOT AFFECTED.

1 Affected Product

Vehicle

| MAKE | MODEL | YEAR |
|------|-------|------|
| RAM | 1500 | 2015 |

July 8, 2020 NHTSA ID NUMBER: 11338210

Components: STEERING, ELECTRICAL SYSTEM, STRUCTURE

NHTSA ID Number: 11338210

Incident Date May 24, 2020

Consumer Location PALATINE, IL

Vehicle Identification Number 1C6RR7FT9HS*****

Summary of Complaint

CRASHYes

FIRENo

INJURIES0

DEATHS0

WHEN BACKING INTO GARAGE ON 5/24/20 RAM 1500 QUAD CAB STEERING LOCKED IN ONE POSITION AND VEHICLE ACCELERATOR WENT TO THE FLOOR. VEHICLE ACCELERATED QUICKLY BACKWARDS INTO MY GARAGE WALL AND DAMAGED THE GARAGE WALL, GARAGE DOOR, AND VEHICLE. I WAS ABLE TO STOP THE VEHICLE PRIOR TO IT HITTING THE BACK OF THE GARAGE AND GOING INTO MY HOUSE. THE VEHICLE STEERING WAS STILL LOCKED AND THE VEHICLE WOULD NOT GO BACK INTO GEAR. HAD THE VEHICLE TOWED TO THE

DEALERSHIP.

1 Affected Product

Vehicle

| MAKE | MODEL | YEAR |
|------|-------|------|
| RAM | 1500 | 2017 |

April 30, 2023 NHTSA ID NUMBER: 11519695

Components: STEERING, ELECTRICAL SYSTEM, FORWARD COLLISION AVOIDANCE

NHTSA ID Number: 11519695

Incident Date April 11, 2023

Consumer Location SPRING VALLEY, NY

Vehicle Identification Number 1C6SRFJT4MN*****

Summary of Complaint

CRASHYes

FIRENo

INJURIES0

DEATHS0

I had issues with the electrical systems on various occasions. There were times when the vehicle shut down in middle of driving while other times some functions such as keyless entry or auto braking didn't work. I took the vehicle to the dealership on 3 separate occasions and they said that they could not recreate the issues but rewired the system. I still had issues and was told that as long as the engine light is not blinking it is safe to drive. On 4/11/2023 while driving full speed on the highway, the electrical system stopped and i lost brakes and steering. This caused me to crash into the car in front of me. In addition, the auto braking did not engage and the airbags did not deploy

1 Affected Product

Vehicle

| MAKE | MODEL | YEAR |
|------|-------|------|
| RAM | 1500 | 2021 |

September 12, 2020 NHTSA ID NUMBER: 11354536

Components: STEERING

NHTSA ID Number: 11354536

Incident Date September 10, 2020

Consumer Location LODA, IL

Vehicle Identification Number 3C6JR7AT2DG*****

Summary of Complaint

CRASHYes

FIRENo

INJURIES0

DEATHS0

MY 2013 DODGE RAM 1500 SUDDENLY LOST POWER STEERING WHILE IN MOTION CAUSING ME TO ENTER A DITCH AND MY VEHICLE SUFFERED MINOR DAMAGE. THE VEHICLE STILL RUNS FINE BUT THE EMERGENCY LIGHT IS STILL ON AND THERE IS NO POWER STEERING. ONLINE RESEARCH SHOWED MOPAR KNOWS THIS IS AN ISSUE WITH 2013-2015 MODELS AND RECALLS EXIST BUT MY VIN SHOWS NO SUCH RECALL. LIVES WILL BE LOST IF THIS ISSUE IS NOT ADDRESSED. MY VEHICLE ONLY HAS 70,000 MILES ON IT AND INSTANT POWER STEERING LOSS ON A FULLY FUNCTIONAL VEHICLE IS VERY CONCERNING. IF SOMEONE IS ON A CURVE AS I WAS THERE IS NO WAY TO NAVIGATE THE SITUATION.

1 Affected Product

Vehicle

| MAKE | MODEL | YEAR |
|------|-------|------|
| RAM | 1500 | 2013 |

September 28, 2020 NHTSA ID NUMBER: 11361622

Components: STEERING, STRUCTURE

NHTSA ID Number: 11361622

Incident Date February 18, 2019

Consumer Location SHOREVIEW, MN

Vehicle Identification Number 1C6RR7LG4ES*****

Summary of Complaint

CRASHYes

FIRENo

INJURIES0

DEATHS0

FEBRUARY OF 2019 I WAS DRIVING MY 2014 RAM 1500 3.6LITER 4X4 TO WORK. WHEN COMING DOWN AN ON RAMP MY VEHICLE WOULD NOT TURN BACK TO THE RIGHT. I HAD TO MUSCLE THE STEERING TO TRY AND TURN RIGHT BEFORE CAUSING AN ACCIDENT. THE STEERING SUDDENLY TURNED RIGHT SHARPLY SENDING MY VEHICLE HARD RIGHT INTO THE DITCH. THERE WAS NO WARNING LIGHTS OR MAINTANCE WARNING LIGHTS ON THE DASH. I WAS ACCELERATING WHEN ALL OF THIS HAPPENED AND LET OFF ONCE THE TRUCK REFUSED TO RESPOND. THE FACT THAT LATER MODELS ARE BEING ADDRESSED AND YET

2014 OWNERS ARE REPORTING THE ISSUE AS WELL IS PURE NEGLECT.

1 Affected Product

Vehicle

| MAKE | MODEL | YEAR |
|------|-------|------|
| RAM | 1500 | 2014 |

December 7, 2020 NHTSA ID NUMBER: 11378321

Components: STEERING

NHTSA ID Number: 11378321

Incident Date March 2, 2020

Consumer Location SANTA CLARITA, CA

Vehicle Identification Number 1C6RR6GT0DS****

Summary of Complaint

CRASHYes

FIRENo

INJURIES0

DEATHS0

TL* THE CONTACT OWNS A 2013 DODGE RAM 1500. THE CONTACT STATED THAT WHILE DRIVING AND HE STOPPED TO MAKE A LEFT HAND TURN. THE POWER STEERING MALFUNCTIONED AND CONTINUED TO TURN THE VEHICLE TO THE LEFT. THE CONTACT ATTEMPTED TO CORRECT THE TURN SINCE ONCOMING TRAFFIC WAS HEADED THAT WAY AND VEHICLE CRASHED INTO A PARKED VEHICLE. THERE WERE NO INJURIES THAT REQUIRED HOSPITALIZING. A POLICE REPORT WAS NOT FILED. THE VEHICLE'S ENTIRE FRONT WAS DAMAGED WITH THE FENDER. THE GRILL, THE HEADLIGHTS, THE BUMPER AND THE TWO FRONT CONTROL ARMS WERE DAMAGED. THE VEHICLE WAS TOWED TO THE CONTACT'S HOME. THE DEALER BALLEY CAR PLANET 14329 VICTORY BLVD, VAN NUYS, CA 91401 (818) 892-1422 DENIED ANY HELP BECAUSE THEY SAID THE VEHICLE'S WARRANTY HAD EXPIRED. THE MANUFACTURER OFFERED A TRADEIN TO THE CONTACT FOR A NEW TRUCK. THE FAILURE MILEAGE WAS 70,000. THERE WERE THREE OTHER RECALLS ON THE VEHICLE. THE VEHICLE WAS BEING REPAIRED BY THE CONTACT. *DT*JB

1 Affected Product

Vehicle

| MAKE | MODEL | YEAR |
|------|-------|------|
| RAM | 1500 | 2013 |

August 8, 2023 NHTSA ID NUMBER: 11537134

Components: STEERING, SUSPENSION, ELECTRONIC STABILITY CONTROL (ESC)

NHTSA ID Number: 11537134

Incident Date January 17, 2023

Consumer Location WETHERSFIELD, CT

Vehicle Identification Number 1C6SRFRT5MN****

Summary of Complaint

CRASHYes

FIRENo

INJURIES1

DEATHS0

The contact owns a 2021 Ram 1500. The contact stated that while driving at 45 MPH, the contact noticed that the wheel became stiff and was unable to turn. The contact attempted to pull over but crashed into the side of the road. The air bags did not deploy. The contact was unaware of how fast they were driving at the time of the crash. The contact sustained a shoulder and neck injury from the seatbelt. Physical therapy and MRI medical treatment were needed for the injury. No police report was filed. The vehicle displayed warning messages for power steering wheel unavailable suspension system unavailable and electronic stability control unavailable. The vehicle was towed to a dealer. The dealer was not able to diagnose the failure. The vehicle was not repaired as of yet. The manufacturer was made aware of the failure and sent a Team to inspect the vehicle but the failure was not detected. The failure mileage was 36,000.

1 Affected Product

Vehicle

| MAKE | MODEL | YEAR |
|------|-------|------|
| RAM | 1500 | 2021 |

October 2, 2023 NHTSA ID NUMBER: 11547778

Components: POWER TRAIN

NHTSA ID Number: 11547778

Incident Date November 22, 2022

Consumer Location MORRISTOWN, AZ

Vehicle Identification Number 1C6RR7MT4JS****

Summary of Complaint

CRASHYes

FIRENo

INJURIES0

DEATHS0

The contact owns a 2018 RAM 1500. The contact stated that while driving at 80 MPH, she heard an abnormal clicking sound and upon attempting to decrease in speed by depressing the brake pedal, the vehicle failed to slow down. The steering wheel then failed to function and control of the vehicle was lost. As a result, the vehicle careened off the road and into a barrier wall. The air bags did not deploy. A police report was filed, and no injuries were reported. No warning lights were illuminated. The vehicle was towed to an independent mechanic, who diagnosed that the actuator had broken in half. The vehicle was not repaired. The manufacturer was not notified of the failure. The failure mileage was 90,000.

1 Affected Product

Vehicle

| MAKE | MODEL | YEAR |
|------|-------|------|
| RAM | 1500 | 2018 |

May 12, 2021 NHTSA ID NUMBER: 11416332

Components: STEERING

NHTSA ID Number: 11416332

Incident Date April 15, 2021

Consumer Location CLEBURNE, TX

Vehicle Identification Number 1C6RR7KM7KS****

Summary of Complaint

CRASHYes

FIRENo

INJURIES0

DEATHS0

TL* THE CONTACT OWNS A 2019 RAM 1500. THE CONTACT STATED THAT WHILE DRIVING AT APPROXIMATELY 5 MPH, THE STEERING WHEEL SEIZED WITHOUT WARNING CAUSING THE VEHICLE TO CRASH INTO A TELEPHONE POLE. THE AIR BAGS DID NOT DEPLOYED. A POLICE REPORT WAS NOT FILED. THE CONTACT STATED THAT THERE WERE NO INJURIES. THE VEHICLE WAS TOWED TO SOUTHWEST CHRYSLER DODGE JEEP RAM LOCATED AT 2235 N MAIN ST, CLEBURNE, TX 76033 WHERE IT WAS DIAGNOSED THAT THE RACKET STEERING PINION WAS LOCK AND NEEDED TO BE REPLACED. THE VEHICLE WAS REPAIRED. THE MANUFACTURER WAS NOTIFIED OF THE FAILURE AND PROVIDED A CASE NUMBER. THE APPROXIMATE FAILURE MILEAGE WAS 7,500.

1 Affected Product

Vehicle

| MAKE | MODEL | YEAR |
|------|-------|------|
| RAM | 1500 | 2019 |

July 20, 2022 NHTSA ID NUMBER: 11474934

Components: STEERING, AIR BAGS

NHTSA ID Number: 11474934

Incident Date June 29, 2022

Consumer Location DUBBERLY, LA

Vehicle Identification Number N/A

Summary of Complaint

CRASH Yes

FIRE No

INJURIES 1

DEATHS 0

The contact's daughter owns a 2014 Dodge Ram 1500. The contact stated while driving at 55 MPH with her children sitting in the front passenger and rear passenger seats, the vehicle in front of her stopped inadvertently. The contact's daughter depressed the brake pedal and attempted to quickly veer to the side of the road to prevent her vehicle from crashing into the vehicle in front of her. However, the steering wheel locked and the vehicle crashed into the rear end of the vehicle in front of her. The air bags failed to deploy. The message "Malfunctioning Steering" was displayed. The bumper and front grill of the vehicle detached. The contact's daughter sustained bruises and soreness all over the body. The contact was unsure whether his grandchildren sustained injuries. The passenger of the other vehicle did not sustain injuries. A police report was filed. The contact's daughter was taken to the hospital with the assistance of emergency units. The vehicle was towed to a tow yard. The vehicle was then towed to the contact's residence. An unknown Dodge dealer was notified of the vehicle but provided no assistance. The manufacturer was notified of the failure and a case was opened. The contact was awaiting a call back from the manufacturer. The vehicle was not diagnosed or repaired. The failure mileage was approximately 100,000. The VIN was not available.

1 Affected Product

Vehicle

| MAKE | MODEL | YEAR |
|------|-------|------|
| RAM | 1500 | 2014 |

September 30, 2021 NHTSA ID NUMBER: 11435026

Components: STEERING

NHTSA ID Number: 11435026
Incident Date August 25, 2021
Consumer Location TERRE HAUTE, IN
Vehicle Identification Number 1C6SRFU99MN****

Summary of Complaint

CRASHYes
 FIRENo
INJURIES0
 DEATHS0

Driving 30-35mph in city streets the truck suddenly could not be steered. The steering wheel could be moved lock to lock with one finger with seemingly no connection to the steering mechanism. The truck pulled to the right, striking several parked cars with the right front end of the truck. The police officer who made the report felt the steering wheel problem was the likely cause of the accident. There was no warning ahead of time such as dashboard warning lights, noise, smoke or other symptoms. The truck remains in a local body shop where the owner noted that he had never seen a similar steering wheel symptom in impacts much more extreme than 30-35 mph. Further inspection once the truck was placed on a lift reveals the steering column was snapped in two at the level of the firewall. Again, the body shop owner and his staff have never seen that occur before in any vehicle. Obviously a vehicle that suddenly loses steering control while moving is a clear and present danger for any occupants of my vehicle as well as anyone in nearby vehicles, thus my concern. I did report this immediately to FCA (Dodge) and they assigned an incident report but at the time I notified NHTSA 4 weeks after the accident, they had not ever gotten back to me.

1 Affected Product

Vehicle

| MAKE | MODEL | YEAR |
|------|-------|------|
| RAM | 1500 | 2021 |

February 18, 2022 NHTSA ID NUMBER: 11452810

Components: STEERING, VEHICLE SPEED CONTROL, SERVICE BRAKES

NHTSA ID Number: 11452810
Incident Date February 12, 2022
Consumer Location LIVONIA, MI
Vehicle Identification Number 1c6rrffg1ln****

Summary of Complaint

CRASHYes
 FIRENo
INJURIES3
 DEATHS0

Truck was going at 40 MPH and power steering went out, brakes went out and truck started to

accelerate resulting in a serious crash. Vehicle was totaled out but not inspected by Dodge. There was no warning of any problems with truck.

1 Affected Product

Vehicle

| MAKE | MODEL | YEAR |
|------|-------|------|
| RAM | 1500 | 2020 |

March 7, 2022 NHTSA ID NUMBER: 11455517

Components: STEERING

NHTSA ID Number: 11455517

Incident Date March 4, 2022

Consumer Location Unknown

Vehicle Identification Number 1C6RR7TT8KS****

Summary of Complaint

CRASHYes

FIRENo

INJURIES0

DEATHS0

my power steering doesn't work properly on my 2019 Ram 1500 classic. when i drive it goes in and out of power steering. i see there is a recall for FCA US has decided that a defect, which relates to motor vehicle safety, exists in certain Electric Power Steering (EPS) gears intended for use on 2013 – 2019 Model Year (DS) Ram 1500 pickup trucks. Some EPS gear assemblies may have been built with a contaminated circuit card assembly that may short circuit. A short in the control circuit components may result in an intermittent loss of power steering assist which may cause an inconsistent steering effort, especially during lower speed maneuvers. Inconsistent steering effort can cause a vehicle crash without prior warning but both FCA and Duluth dodge refuse to inspected the vehicle because they say its not part of the recall.... but it was manufactured in 11/18 which falls into the time period

1 Affected Product

Vehicle

| MAKE | MODEL | YEAR |
|------|-------|------|
| RAM | 1500 | 2019 |

July 1, 2022 NHTSA ID NUMBER: 11472021

Components: STEERING

NHTSA ID Number: 11472021

Incident Date June 27, 2022

Consumer Location EATON, NY

Vehicle Identification Number 1C6RR7FG1ES****

Summary of Complaint

CRASHYes

FIRENo

INJURIES0

DEATHS0

The rack and pinion which is electronic failed and caused me to crash because it could not steer. There are 1500 plus other vehicles waiting for the same part. Which you can't get a new one because they are on back order. But with that many vehicles waiting for the same part it should be a recall on them.

1 Affected Product

Vehicle

| MAKE | MODEL | YEAR |
|------|-------|------|
| RAM | 1500 | 2014 |

September 28, 2022 NHTSA ID NUMBER: 11486893

Components: STEERING

NHTSA ID Number: 11486893

Incident Date September 28, 2022

Consumer Location BILLINGS, MT

Vehicle Identification Number 1C6RR7VT9DS****

Summary of Complaint

CRASHYes

FIRENo

INJURIES0

DEATHS0

THE ELECTRONIC POWER STEERING GEAR FAILED. THAT IS THE STEERING WHEEL LOCKED UP ON ME FIVE TIMES WHILE I WAS ON MY WAY HOME. IT PUT ME INTO THE DITCH AND THE SIDE OF HILL THREE OF THOSE FIVE. HAD THERE BEEN ANY ON COMING TRAFFIC THIS COULD HAVE VERY EASILY TURNED INTO A HEADON COLLISION AS THESE EVENTS CAUSED TOTAL AND COMPLETE LOSS OF ABILITY TO STEER OR CONTROL THE TRUCK. LITHIA DODGE IN BILLINGS MONTANA HAS CONFIRMED THE FAILURE OF THE EPS SYSTEM. THE ONLY PEOPLE TO INSPECT THIS ISSUE HAS BEE THE LITHIA DODGES LINE TECHS.THERE WERE NO WARNING LAMPS OR ANY OTHER INDICATIONS OF EMMINENT FAILURE. THIS VEHICLE COULD HAVE KILLED US. LITHIA DODGE HAS TOLD US THAT THERE ARE NO RECALLS ON THIS VEHICLE.. KEEP TRYING TO TELL US THIS IS GOING TO COST 4700.00 THE FIRST TIME THEN 2400. I THINK IT IS. BUT THIS IS A VERY SERIOUS SAFETY ISSUE, IF THERE IS A FAILURE OF THIS

COMPONENT. WHY DOES IT NOT ALLOW A MANUEL OVERRIDE TO OCCUR WHICH WOULD ALLOW THE DRIVER TO AT LEAST STEER THIS THING. AND IM BEING TOLD THAT THEY, WILL NOT HONOR THE RECALL..... I DO NOT BELIEVE THEY REMOVED THE SKID PLATE AND REFERENCED THE NUMBER ON THE STEERING GEAR UNIT TO THE NUMBERS LISTED ON THE VB8 RECALL INSTRUCTIONS.

1 Affected Product

Vehicle

| MAKE | MODEL | YEAR |
|------|-------|------|
| RAM | 1500 | 2013 |

October 19, 2022 NHTSA ID NUMBER: 11489907

Components: STEERING, ELECTRICAL SYSTEM, UNKNOWN OR OTHER

NHTSA ID Number: 11489907

Incident Date March 26, 2022

Consumer Location CORPUS CHRISTI, TX

Vehicle Identification Number 1c6rr6gt3es****

Summary of Complaint

CRASHYes

FIRENo

INJURIES1

DEATHS0

INTERSECTION,I PROCEEDED TO TURN LEFT, THE WHEEL TURNED TO THE RIGHT AND LOCKED i STRUIGGLED TO CONTROLD THE VEHICLE, DESPERATELY TRYING NOT TO HIT A MAN CROSSING THE STREET IN A WHEELCHAIR. i LOST CONTROL, JUMPED A CURVE AND HIT A LIGHT POLE. MY FACE HIT THE STEERING WHEEL. FOUR OF MY TEETH WERE KNOCKED LOOSE. IHAD TO HAVE THEM PULL DUE TO AN INFECTION. MY HEAD AND NECK WAS JERKED AROUND TWICE. I WAS IN SHOCK & TERRIFIED I DROVE HOME CALLED MY SON, HE IMMEDIATELY CAME TO DRIVE THE TRUCK TO MY HOME, I MANAGED. MY DENTIST PULLED THREE TEETH AND THEN ONE MORE BECAUSE THEY BECAME INFECTED. THIS STEERING PROBLEM WAS NOT NORMAL., NO FLUID LOSS, NO WARNING. MY TRUCK HAD BEEN IN THE SHOP 4-6 WEEKS PRIOR A COMPLETE DIAGNOSIS WAS CONDUCTED. THERE WAS NO INDICATION THAT THIS WAS AN ISSUE, HAD I TURN TO THE RIGHT I WOULD HAVE CAUSED A MAJOR ACCIDENT ON THE FREEWAY. INSTEAD OF GOING HOME THAT NIGHT i WAS GOING TO SEE MY 6 YEAR OLD GRANDDAUGHTER. MY INSURANCE COMPANY TOLD ME TO PLACE IN THE SHIOP. AFTER THE REPAIRS THEY SAID THEY WOULD NOT COVER THE \$5,000 REPAIR BECAUSE THEY DISCOVERED IT WAS A WEAR AND TEAR. THIS IS FALSE. I CALLED FCA they informed me that my warranty was out. I telephoned them several times to inform them this was not a warranty issue. The same issue for the recall,

reoccurred. it wasn't until I informed them of my injury, then they informed me they would send someone to investigate. They sent their Engineering Analysis associates/Bosch Automotive Services Solutions to exam the repaired vehicle. It was at that point they read the report from Lithia Dodge Ram, the dealer my deceased husband purchased this death trap and examined it, but they could not find no evidence of a manufacturing issue, no evidence of power steering, electrical nor the throttle. Well, this is a problem because my invoice I was given and I was advised the report code stated it was electrical steering rack, a manufacturer problem THOUSANDS COMPLAINED. #ACCOUNTABILITY!

1 Affected Product

Vehicle

| MAKE | MODEL | YEAR |
|------|-------|------|
| RAM | 1500 | 2014 |

January 19, 2023 NHTSA ID NUMBER: 11502583

Components: STEERING

NHTSA ID Number: 11502583

Incident Date December 25, 2022

Consumer Location Unknown

Vehicle Identification Number 1C6SRFFTXNN****

Summary of Complaint

CRASHYes

FIRENo

INJURIES0

DEATHS0

The contact owns a 2022 Ram 1500. The contact stated that while driving at an undisclosed speed, the vehicle experienced a loss of power steering assist. The vehicle crashed into trees. No air bags were deployed. There were no injuries. No Police report was filed. The vehicle was towed to the dealer; however, it was not diagnosed or repaired. The manufacturer was not made aware of the failure. The failure mileage was approximately 25,000.

1 Affected Product

Vehicle

| MAKE | MODEL | YEAR |
|------|-------|------|
| RAM | 1500 | 2022 |

February 3, 2023 NHTSA ID NUMBER: 11505359

Components: STEERING**NHTSA ID Number:** 11505359**Incident Date** July 16, 2022**Consumer Location** Unknown**Vehicle Identification Number** 1C6RR6LT3FS******Summary of Complaint**

CRASHYes

FIRENo

INJURIES2

DEATHS0

My Steering went suddenly stiff making it extremely hard to turn, this resulted to my truck clipping/crashing into the front side of a parked commercial vehicle. My car rolled over and me and my passenger was injured. The truck was inspected and the technicians final conclusion was that the accident took place because the electronic power steering lost communication.

1 Affected Product

Vehicle

| MAKE | MODEL | YEAR |
|------|-------|------|
| RAM | 1500 | 2015 |

March 22, 2023 NHTSA ID NUMBER: 11513272

Components: STEERING**NHTSA ID Number:** 11513272**Incident Date** March 22, 2023**Consumer Location** Unknown**Vehicle Identification Number** 1C6RR7LT8FS******Summary of Complaint**

CRASHYes

FIRENo

INJURIES0

DEATHS0

The contact owns a 2015 Ram 1500. The contact stated that while driving 30 MPH in inclement weather, the power steering assist failed without warning going around a curve. Due to the failure, the contact drove into a ditch which caused minor damages to the front end of the vehicle. The air bags did not deploy. There was no injury sustained. A police report was not filed. The contact used excessive force to steer the vehicle to her destination. The dealer and the manufacturer were notified of the failure, and the contact was informed that there were no recalls on the vehicle. Upon investigation, the contact discovered NHTSA Campaign Number: 16V167000 (Steering) which she linked to the failure. The vehicle was not repaired. The failure mileage was approximately 148,000.

1 Affected Product

Vehicle

| MAKE | MODEL | YEAR |
|------|-------|------|
| RAM | 1500 | 2015 |

August 8, 2023 NHTSA ID NUMBER: 11537136

Components: **STEERING**

NHTSA ID Number: 11537136

Incident Date December 16, 2020

Consumer Location Unknown

Vehicle Identification Number 3C6JR6ATXGG****

Summary of Complaint

CRASHYes

FIRENo

INJURIES2

DEATHS0

The Traction control flashed immediately before the wreck so my assumption is there was a traction lock malfunction. The road was wet due to rain. My husband was driving 55 mph when the truck's steering locked and we ended up in the right side ditch where we hit an electric power pole. My husband had several fractured ribs. My right lower arm was broken, required surgery and a week long stay in the hospital. They put a rod with screws into my arm. The truck was totally destroyed according to our insurance company.

1 Affected Product

Vehicle

| MAKE | MODEL | YEAR |
|------|-------|------|
| RAM | 1500 | 2016 |

August 14, 2023 NHTSA ID NUMBER: 11538294

Components: **STEERING**

NHTSA ID Number: 11538294

Incident Date June 22, 2023

Consumer Location RALEIGH, NC

Vehicle Identification Number 1C6RR6KT0ES****

Summary of Complaint

CRASHYes

FIRENo

INJURIES0

DEATHS0

Driving down the the highway of Creedmoor Road in Raleigh, NC, I had a sudden loss of power steering and hit a guard rail. Luckily, the only damage was to the front bumper. I took the vehicle into my local garage and they said that the power steering is Electronically controlled by the Rack and Pinion and that it had failed. The parts are nearly \$3,000. My truck only has 80k miles on it. Looking throughout various forums, it seems that this is happening to many others as well with various amounts of miles. Until right now, my truck still has no power steering and is undriveable. The part is not available for purchase. This is a very dangerous situation. Had it been my wife driving, she would not have been able to control the steering as the v8 weighing on the front wheels makes it difficult to turn at all.

1 Affected Product

Vehicle

| MAKE | MODEL | YEAR |
|------|-------|------|
| RAM | 1500 | 2014 |

August 21, 2023 NHTSA ID NUMBER: 11539766

Components: STEERING**NHTSA ID Number:** 11539766**Incident Date** August 19, 2023**Consumer Location** UNIVERSITY HEIGHTS, OH**Vehicle Identification Number** 1C6RR7MT7GS******Summary of Complaint**

CRASHYes

FIRENo

INJURIES0**DEATHS0**

The contact owns a 2016 Ram 1500. The contact stated that while driving at at 25 MPH, the steering wheel tightened without warning. The contact used excessive force to untighten the steering wheel; the power steering assist returned to normal operation. The contact replaced the ball joints, inner tie rods, and several other parts in the vehicle after the failure. A year after the initial failure, the contact stated that while driving at 50 MPH, the same failure occurred again without warning. Due to the failure, the contact hit a a curb and damaged the front end of the vehicle. The air bag did not deploy; the contact was not injured. A police report was not filed. The vehicle was towed to his home where it remained in his possession. Upon investigation, the contact discovered NHTSA Campaign Number: 16V167000 (Steering); however, the manufacturer was notified of the failure and informed him that there were no recalls on the vehicle. The vehicle had yet to be repaired. The failure mileage was approximately 76,000.

1 Affected Product

Vehicle

| MAKE | MODEL | YEAR |
|------|-------|------|
| RAM | 1500 | 2016 |

September 30, 2023 NHTSA ID NUMBER: 11547528

Components: STEERING

NHTSA ID Number: 11547528

Incident Date September 28, 2023

Consumer Location SAN ANGELO, TX

Vehicle Identification Number 1C6RR6FG8JS****

Summary of Complaint

CRASHYes

FIRENo

INJURIES0

DEATHS0

Three times since January 2023, the steering has locked down while driving. The driver has had no control over steering momentarily. The latest incident caused the vehicle to strike a concrete pillar surrounding a stop sign in a parking lot.

1 Affected Product

Vehicle

| MAKE | MODEL | YEAR |
|------|-------|------|
| RAM | 1500 | 2018 |

October 19, 2023 NHTSA ID NUMBER: 11550776

Components: STEERING

NHTSA ID Number: 11550776

Incident Date October 19, 2023

Consumer Location MIAMI, FL

Vehicle Identification Number 1C6RR7LM2ES****

Summary of Complaint

CRASHYes

FIRENo

INJURIES0

DEATHS0

mild crash! my Ram 1500 pickup trucks can lose power-steering with no warning. I could NOT turn!

1 Affected Product

Vehicle

| MAKE | MODEL | YEAR |
|------|-------|------|
| RAM | 1500 | 2014 |

December 24, 2023 NHTSA ID NUMBER: 11561676

Components: STEERING, ELECTRICAL SYSTEM

NHTSA ID Number: 11561676

Incident Date November 23, 2023

Consumer Location DALLAS, TX

Vehicle Identification Number 1C6RR6KT3ES****

Summary of Complaint

CRASHYes

FIRENo

INJURIES0

DEATHS0

Was driving one day while towing a trailer and all of a sudden while making a left turn the power steering went out which caused me to hit an embankment and damage the front bumper area of my vehicle. My safety was put at risk because of the damage it caused and how difficult the steering became all of a sudden without warning or anything. There weren't any warning prior to the power steering going out, but as soon as it went out a symbol appeared on the dashboard. This was the first time that I have ever seen that symbol. Vehicle hasn't been inspected by anybody other than myself. Checked for recalls and saw that my 2014 wasn't included.

1 Affected Product

Vehicle

| MAKE | MODEL | YEAR |
|------|-------|------|
| RAM | 1500 | 2014 |

January 5, 2024 NHTSA ID NUMBER: 11563695

Components: STEERING

NHTSA ID Number: 11563695

Incident Date December 9, 2023

Consumer Location Unknown

Vehicle Identification Number 1C6RR7MT7JS****

Summary of Complaint

CRASHYes

FIRENo

INJURIES0

DEATHS0

1. Electronic power steering rack and pinnion and the control module on the rack for power steering. Yes vehicle is available for inspection. 2. While driving 100km (62miles)/hr on a highway lost all steering control and was forced to hit the ditch to avoid a roadway curve and oncoming traffic. Brakes functioned but steering did not. Putting my families lives and others at risk of a vehicle collision. No injuries were sustained. 3. Steering control issues has been confirmed by a dealership and mechanic shop. 4. Unknown if it has been inspected by authorities generically. My vehicle has not been inspected other than by dodge and an independent service provider. 5. After power steering failed, check engine dash light has come on, not allowing command start or other functions to be used. Dash does not have any messages and had to have code read by dealership to find steering control failure. Was advised that dodge rams up to 2017 have had the exact same recall for ower steering failures. 2018s should be investigated for the power steering failures as well.

1 Affected Product

Vehicle

| MAKE | MODEL | YEAR |
|------|-------|------|
| RAM | 1500 | 2018 |

C. FCA’s Knowledge of the Power Steering Defect

1. NHTSA Complaints

45. An important source of field data for FCA is the NHTSA’s Consumer Complaint Database. FCA routinely monitors NHTSA Complaints concerning its vehicles similar in substance to those quoted below. Moreover, FCA’s customer relations personnel and quality engineers routinely monitor and reviews NHTSA Complaints relating to its vehicles, as well as customer complaints existing on other internet forums, such as social media websites, consumer websites, and automotive blogs. FCA’s customer relations division regularly receives and responds to customer calls and internet complaints concerning, *inter alia*, product defects.

Class Vehicle owners have submitted at least 1,090 NHTSA Complaints citing power steering

loss.²

2. FCA's Inadequate Safety Recalls

46. FCA also knew or should have known of the Power Steering Defect because of prior recalls and internal investigations into the problem.

47. On August 25, 2015, FCA opened an internal investigation into the Power Steering Defect for the 2015-2016 Ram 1500 trucks, based on returned EPS Units and complaints of loss of power steering.³ As a result of the investigation, on March 22, 2016, FCA issued a recall campaign for 442 Ram 1500 trucks manufactured between 2015-2016.⁴ At the time, FCA claimed that this sub-set of trucks had been manufactured with contaminated circuit boards, which could cause the EPS Unit (and the entire power steering system) to short circuit and fail.

48. Then, in November 2019, FCA issued another recall campaign ("2019 Recall") due to reports of power steering failure, this time for certain 2019 RAM 1500s.⁵ FCA's dealer service instructions and explanation for the 2019 Recall were almost identical to the 2016 Recall. Again, FCA claimed that power steering loss from "contamination" of the EPS unit, which only affected 190 vehicles.⁶ But FCA's causal explanation for the Power Steering Defect, and the sparse number of vehicles supposedly affected by it, cannot be reconciled with the ever-increasing number of Class Vehicle owners experiencing the problem.

3. Elevated Warranty Claims and High Service Part Demand

49. Moreover, FCA knew or should have known about the Power Steering Defect because it regularly interacts with authorized service technicians to identify potentially widespread

² Ex. 1, Relevant NHTSA Vehicle Owner Questionnaires

³ Ex. 2, FCA US LLC Chronology EPS Control Circuit Board

⁴ Ex. 3, Part 573 Safety Recall Report for NHTSA Recall 16V-167.

⁵ Ex. 4, Part 573 Safety Recall Report for NHTSA Recall 19V-812.

⁶ Compare Ex. 5, Dealer Service Instructions for NHTSA Recall 16V-167 with, Ex. 6, Dealer Service Instructions for NHTSA Recall 19V-812.

vehicle problems and assist in diagnosing vehicle issues. From these interactions, FCA also collects and analyzes field data including, but not limited to, repair requests made at dealerships and service centers, technical reports prepared by engineers that have reviewed vehicles for which warranty coverage is requested, parts sales reports, and warranty claims data.

50. FCA's warranty department similarly reviews and analyzes warranty data submitted by its dealerships and authorized technicians to identify defect trends in its vehicles. It dictates that when a repair is made under warranty (or warranty coverage is requested), service centers must provide it with detailed documentation. It also requires service centers to save the broken parts in case the dealership is audited, or otherwise acts to verify the warranty repair. For their part, service centers are meticulous about providing this detailed information about in-warranty repairs because FCA will withhold payment if the complaint, cause, and correction are not sufficiently described.

51. As expressed through the NHTSA Complaints below, the electric power steering rack and pinion service part for the Class Vehicles has been on national backorder and/or extremely difficult for FCA's dealerships and Class Vehicle owners to obtain for quite some time. Many Classes Vehicles owners report waiting months for the part. Such high demand for this part is monitored and known to FCA, and further indicates its knowledge of the Power Steering Defect.

May 2, 2023 NHTSA ID NUMBER: 11520082

Components: STEERING

NHTSA ID Number: 11520082

Incident Date April 21, 2023

Consumer Location MAROA, IL

Vehicle Identification Number 1C6RR7LT2DS****

Summary of Complaint

CRASHNo

FIRENo

INJURIES0

DEATHS0

The contact owns a 2013 Ram 1500. The contact stated that while her husband was driving at approximately 30 MPH, the vehicle experienced a loss of power steering, which caused her

husband to almost crash into another vehicle. The power steering warning light was illuminated. The vehicle was taken to a local dealer, where it was diagnosed that the power steering rack assembly needed to be replaced; however, the part for the repair was on backorder. The vehicle was then taken to an independent mechanic, who also confirmed the previous mechanic's diagnosis and that the part for the repair was on backorder. The vehicle was not repaired. The manufacturer was made aware of the failure and advised the contact to file a complaint with the NHTSA Hotline. The approximate failure mileage was 100,000.

1 Affected Product

Vehicle

| MAKE | MODEL | YEAR |
|------|-------|------|
| RAM | 1500 | 2013 |

August 25, 2023 NHTSA ID NUMBER: 11540781

Components: STEERING

NHTSA ID Number: 11540781

Incident Date December 21, 2022

Consumer Location WOODLAND, CA

Vehicle Identification Number 1C6RR7NT1FS****

Summary of Complaint

CRASHNo

FIRENo

INJURIES0

DEATHS0

The electronic power steering rack failed. It became dangerous as the power steering would go in and out, therefore, putting myself and others at the risk of a collision or crash. The dodge dealership was able to replace the unit, but it took 1-1/2 months as the part was on backorder and it cost \$3,600. There was a recall on this exact issue for my same model and year, however, I was told my truck was not part of the recall.

1 Affected Product

Vehicle

| MAKE | MODEL | YEAR |
|------|-------|------|
| RAM | 1500 | 2015 |

August 25, 2023 NHTSA ID NUMBER: 11540763

Components: STEERING**NHTSA ID Number:** 11540763**Incident Date** August 3, 2023**Consumer Location** WILLISTON, SC**Vehicle Identification Number** 1C6RR6FT3DS******Summary of Complaint**

CRASHNo

FIRENo

INJURIES0

DEATHS0

Driving on interstate on vacation, we stop for gas and started engine no power steering. Cut off and restarted engine now I have power steering. Stop again to get gas start engine no power steering. Tried cutting off and restarted engine no power steering and still 2 weeks later no power steering and you can't drive this truck without power steering. Checked on getting it replaced and was told the part is on Nation wide backorder. So how is this going to be drivable? Called Ram dealer and they say no recall on this. So many ram trucks are having this issue. Ram should fix this deadly problem they created.

1 Affected Product

Vehicle

| MAKE | MODEL | YEAR |
|------|-------|------|
| RAM | 1500 | 2013 |

September 1, 2023 NHTSA ID NUMBER: 11542121

Components: STEERING**NHTSA ID Number:** 11542121**Incident Date** July 24, 2023**Consumer Location** ORLANDO, FL**Vehicle Identification Number** 1C6RR7FT8ES******Summary of Complaint**

CRASHNo

FIRENo

INJURIES0

DEATHS0

The contact owns a 2014 Ram 1500. The contact stated that after restarting the vehicle, the message "Power Steering Failure" was displayed, and the steering wheel was very difficult to turn in either direction. The vehicle was taken to the local dealer who diagnosed that the steering rack was faulty and needed to be replaced; however, the parts needed to repair the vehicle were on backorder. The vehicle was not repaired. The manufacturer was notified of the failure, but no assistance was offered. The failure mileage was 74,650.

1 Affected Product

Vehicle

| MAKE | MODEL | YEAR |
|------|-------|------|
| RAM | 1500 | 2014 |

September 29, 2023 NHTSA ID NUMBER: 11547292

Components: **STEERING**

NHTSA ID Number: 11547292

Incident Date September 23, 2023

Consumer Location Unknown

Vehicle Identification Number 1C6RR7FG3ES****

Summary of Complaint

CRASHNo

FIRENo

INJURIES0

DEATHS0

On Saturday Sept. 23, 2023 I was driving about 25-30 MPH and the power steering went out. I took the truck to the dealership immediately that day for diagnostics. They said the Power steering rack failed (part #68628858AA) and the part is not available. They said it is on backorder until January 2024 or possibly longer. I picked up the truck that Tuesday, Sept. 26, 2023 to sit in the drive until further notice. The vehicle is available for inspection upon request. My safety and others were put at risk when driving and the power steering went out without notice. I was unable to steer the vehicle in a timely manner, or if I needed to swerve quickly would not have been able to do that. As of right now the vehicle has only been inspected by the dealership. Prior to the steering going out, There was also ABS brake warning light which I had looked at by an independent service center on Aug. 17th, 2023 who determined that I needed a new ABS brake module replace (part #68228991AD).

1 Affected Product

Vehicle

| MAKE | MODEL | YEAR |
|------|-------|------|
| RAM | 1500 | 2014 |

November 16, 2023 NHTSA ID NUMBER: 11555403

Components: **STEERING**

NHTSA ID Number: 11555403

Incident Date November 5, 2023

Consumer Location WESLEY CHAPEL, FL

Vehicle Identification Number 1C6RR6MT0DS****

Summary of Complaint

CRASHNo

FIRENo

INJURIES0

DEATHS0

The contact owns a 2013 Ram 1500. The contact stated while driving approximately 65 MPH, the contact heard a chime and the "Steering Maintenance" warning light was illuminated. The contact continued driving and exited the highway and stopped at an auto parts store where the contact was advised that the power steering was electrically assisted and was referred to a dealer. The contact was able to drive the vehicle to a dealer who diagnosed the vehicle and determined that the power steering assist system needed to be replaced; however, the parts to repair the vehicle were on a national backorder. The vehicle was not repaired. The loss of power steering functionality was constant, and the vehicle was no longer drivable. The manufacturer was informed of the failure. The contact researched online and related the failure to NHTSA Action Number: RQ23003 (Steering). The failure mileage was approximately 100,000.

1 Affected Product

Vehicle

| MAKE | MODEL | YEAR |
|------|-------|------|
| RAM | 1500 | 2013 |

December 21, 2023 NHTSA ID NUMBER: 11561309

Components: STEERING

NHTSA ID Number: 11561309

Incident Date December 11, 2023

Consumer Location SPRING HILL, TN

Vehicle Identification Number 1C6RR7FT8DS****

Summary of Complaint

CRASHNo

FIRENo

INJURIES0

DEATHS0

Driving at 40MPH and 2013 Ram 1500 experienced total and complete loss of power steering with no warning. I was narrowly able to avoid getting into an accident and cannot drive the truck given the strength needed to turn the wheel. Cost from dealer is estimated to be around \$4,500 after parts and labor / taxes and could take months since the part is on backorder. The dealer said there have been multiple issues like this and unfortunately there is not yet a recall other than one from a few years ago that looks very similar to what I experienced. I don't have any other transportation and will likely have to pay to get it fixed. Going to sell it and never buy Ram again.

1 Affected Product

Vehicle

| MAKE | MODEL | YEAR |
|------|-------|------|
| RAM | 1500 | 2013 |

March 26, 2022 NHTSA ID NUMBER: 11458466

Components: **STEERING**

NHTSA ID Number: 11458466

Incident Date March 26, 2022

Consumer Location MUNROE FALLS, OH

Vehicle Identification Number 1C6RR7TT8GS****

Summary of Complaint

CRASHNo

FIRENo

INJURIES0

DEATHS0

I noticed about 2 weeks ago that my steering was becoming difficult. I brushed it off at first, but certain cold mornings, it is becoming harder to steer. My steering wheel also requires force to turn it straight after engaging in a turn, it does not assist. I took it to a National Tire and Battery and they confirmed that my Ram 1500 needs a new rack and pinion. They also informed me that no where around has any in stock, or even know if/when they'll get one. So I am stuck driving a truck where I could lose my steering at any moment. I believe my truck should be a part of 16V-167 recall.

1 Affected Product

Vehicle

| MAKE | MODEL | YEAR |
|------|-------|------|
| RAM | 1500 | 2016 |

June 4, 2022 NHTSA ID NUMBER: 11467525

Components: **STEERING**

NHTSA ID Number: 11467525

Incident Date February 10, 2022

Consumer Location VANCOUVER, WA

Vehicle Identification Number 1C6SRFHTXKN****

Summary of Complaint

CRASHNo

FIRENo

INJURIES
DEATHS

My steering wheel, at high speeds of 60+ mph, would "stick" when turning left, at approximately the 11 to 10 o'clock positions. This stickiness meant the wheel would not return back to center when releasing left turn pressure on its own. It would actually require small amount of force back the other way in which it would "pop" out of the sticky position, causing some very unsafe and scary jerk of the wheels. Both my wife and I experienced it every time the truck was driven on the freeway until we parked the truck due to it being unsafe to drive. I sent the vehicle to the local RAM dealership and they diagnosed it to be an entire "steering rack failure" that would need to be replaced at my cost because the factory warranty time period of 36 months ended, though the mileage period did NOT end as the truck only has 32,000 miles on it. There were no warning lamps or indicators and the truck is 100% stock with no modifications to the wheels, suspension, or drivetrain. The price quoted (not yet the final price) was \$4,200.

1 Affected Product

Vehicle

| MAKE | MODEL | YEAR |
|------|-------|------|
| RAM | 1500 | 2019 |

September 10, 2022 NHTSA ID NUMBER: 11483767

Components: STEERING

NHTSA ID Number: 11483767

Incident Date August 23, 2022

Consumer Location CASA GRANDE, AZ

Vehicle Identification Number 3C6JR6AG3HG****

Summary of Complaint

CRASH**No**

FIRE**No**

INJURIES

DEATHS

The electronic power steering completely failed. After we had been driving and it had been raining we were going about 55 mph down the state highway when the electronic power steering completely failed and we lost control of the steering. The dashboard warning light came on and on the notification screen stated to "service power steering". Even though it shows absolutely no recalls just a simple search online shows that we are not the only ones with a 2017 ram 1500 with electronic power steering with the same issue. I have called around to many auto parts stores and even dealers and nobody has the part in stock. And of course our vehicle having been outside of the five years and mileage it is not under warranty. The steering is 100% locked up and will not move whatsoever. It has been inspected by a authorized ram service mechanic who has verify that it has seized up and needs replaced.

1 Affected Product

Vehicle

| MAKE | MODEL | YEAR |
|------|-------|------|
| RAM | 1500 | 2017 |

October 28, 2022 NHTSA ID NUMBER: 11491254

Components: STEERING

NHTSA ID Number: 11491254

Incident Date August 30, 2022

Consumer Location BOWIE, TX

Vehicle Identification Number 1c6rr6ft6es****

Summary of Complaint

CRASHNo

FIRENo

INJURIES0

DEATHS0

No warning can not steer confirm Patterson of Bowie tx part can be inspected when defective part was removed it had" old" painted on it previouslyin reverse when incident occured new parts out of stock

1 Affected Product

Vehicle

| MAKE | MODEL | YEAR |
|------|-------|------|
| RAM | 1500 | 2014 |

January 10, 2023 NHTSA ID NUMBER: 11501122

Components: STEERING

NHTSA ID Number: 11501122

Incident Date December 18, 2022

Consumer Location Unknown

Vehicle Identification Number 1C6RR7NT3DS****

Summary of Complaint

CRASHNo

FIRENo

INJURIES0

DEATHS0

The E.P.S (electric power steering) failed and cause the steering wheel to lock. This caused a safety issue as I was unable to steer. The vehicle had to be towed, taken to a local repair shop

where ALL the electric components were tested (Battery, computer and wires) This seems to be a problem with Ram trucks as a replacement part is unavailable anywhere and over \$1500. There was no warning of a problem and suddenly it failed which made it impossible to steer and dangerous. This failed component put my life and my family's life in jeopardy

1 Affected Product

Vehicle

| MAKE | MODEL | YEAR |
|------|-------|------|
| RAM | 1500 | 2013 |

February 22, 2023 NHTSA ID NUMBER: 11508625

Components: STEERING

NHTSA ID Number: 11508625

Incident Date January 31, 2022

Consumer Location Unknown

Vehicle Identification Number 1C6RR7LG6GS****

Summary of Complaint

CRASHNo
 FIRENo
 INJURIES0
 DEATHS0

Electric power steering stopped working while parked at a stop light. No previous indication that it was going to go out. No dash indicators. Had to drive home with no power steering with my family in the vehicle. No accident caused. Took the vehicle to a dealer where they informed we needed a new pack and pinion. Ordered one through the dealership and waited 4 months for one before having to move out of state. Got to new state and contacted a dealer who also said they are still on back order and do not know when they will be available. This is a primary vehicle of ours and to not get be able to get ahold of a part because everyone else seems to be having the same problem is very frustrating and inconvenient and a cause of concern. We cannot drive our vehicle without it being unsafe. We have now been out of a vehicle for over a year. 10 months of that year, not being able to get ahold of a new part because they are out of stock. If the part isn't even available for easy repair and people have to wait months in order to receive one because they are in such high demand, that's a obvious fault of the manufacturer on the part and needs to be covered as a recall. I cannot sell my vehicle for a reasonable price because of the issue, I cannot trade in my vehicle for a reasonable price because of the issue and I cannot fix the issue because the part is not available. All at which is not my fault. Our vehicle had approximately 90k miles on it when it went out.

1 Affected Product

Vehicle

| MAKE | MODEL | YEAR |
|------|-------|------|
| RAM | 1500 | 2016 |

July 6, 2023 NHTSA ID NUMBER: 11530758

Components: STEERING

NHTSA ID Number: 11530758

Incident Date July 5, 2023

Consumer Location Unknown

Vehicle Identification Number 1C6RR7FG9GS****

Summary of Complaint

CRASHNo

FIRENo

INJURIES0

DEATHS0

Steering stopped working while driving. Previous year had a recall for this issue and my truck was not included. This is an ongoing problem and the part needed to fix it is unavailable.

1 Affected Product

Vehicle

| MAKE | MODEL | YEAR |
|------|-------|------|
| RAM | 1500 | 2016 |

August 9, 2023 NHTSA ID NUMBER: 11537408

Components: STEERING

NHTSA ID Number: 11537408

Incident Date August 2, 2023

Consumer Location SMITHFIELD, VA

Vehicle Identification Number 3C6JR6AT6DG****

Summary of Complaint

CRASHNo

FIRENo

INJURIES0

DEATHS0

Steering wheel failed to unlock when engine started. Warning lamp appeared, showing locked steering wheel. Transmission would go into gear, however steering wheel was very difficult to turn. I managed to get it to unlock by shutting the engine off and turning the wheel in both

directions and starting the engine back on a few times. Dave's service center inspected my truck and stated the power steering unit was bad. They quoted that the replacement unit from the dealership cost \$4072, however it was out of stock with no timeline of when they would get one in. I spoke with Travis, at Travis auto repair and he stated they could get an after market unit for \$1400.00. I have an appointment with them August 21st to get my truck repair. I was instructed not to drive it as the unit could fail at any time. This first happened on August 2nd and the 6th. The steering wheel currently will not unlock.

1 Affected Product

Vehicle

| MAKE | MODEL | YEAR |
|------|-------|------|
| RAM | 1500 | 2013 |

August 28, 2023 NHTSA ID NUMBER: 11541272

Components: STEERING

NHTSA ID Number: 11541272

Incident Date July 27, 2023

Consumer Location SILOAM SPRINGS, AR

Vehicle Identification Number 1C6RR7GT6DS****

Summary of Complaint

CRASHNo

FIRENo

INJURIES0

DEATHS0

My 2013 Dodge Ram 1500, going down the road and the power steering stopped working, almost got in an accident due to the fact I could barely get the truck turned off the highway. It has been parked now for over a month. Mechanic states it needs a rack and pinion, out of stock everywhere, sounds like a multitude of people are having the same problem.....so Dodge are you going do a recall and stand by your product?????

1 Affected Product

Vehicle

| MAKE | MODEL | YEAR |
|------|-------|------|
| RAM | 1500 | 2013 |

August 30, 2023 NHTSA ID NUMBER: 11541578

Components: STEERING

NHTSA ID Number: 11541578
Incident Date August 1, 2023
Consumer Location Unknown
Vehicle Identification Number 1C6RR6LG6DS****

Summary of Complaint

CRASHNo
 FIRENo
INJURIES0
 DEATHS0

Electric power steering loss leading to loosing control of steering while driving. Steering wheel tightened up and unable to drive safely on the road. Vehicle is currently sitting and unable to drive due to safety hazard. Unable to retrieve parts to fix the problem due to the parts being unavailable/ out of stock

1 Affected Product

Vehicle

| MAKE | MODEL | YEAR |
|------|-------|------|
| RAM | 1500 | 2013 |

D. FCA’s Sales and Service Agreements with its Authorized Dealers

52. FCA manufactures automobiles but does not sell them directly to consumers; instead, FCA vehicles are sold exclusively to authorized FCA dealerships who, in turn, re-sell them to consumers.

53. Persons or entities seeking to become an authorized FCA dealership must complete and submit a dealer application form provided by FCA.

54. Authorized FCA dealerships in the United States are governed by a detailed Sales and Service Agreement.

55. FCA’s authorized dealers are contractually obligated to use best efforts to promote, advertise, and sell FCA’s products to customers, and to take steps to provide service and parts for all FCA products, regardless of where purchased, and whether it is under warranty.

E. FCA Advertised the Class Vehicles as Safe and Reliable While Omitting the Power Steering Defect

56. FCA knowingly advertised, marketed and sold/leased the Class Vehicles with the Power Steering Defect, while willfully omitting and concealing the true inferior quality and substandard performance of the Class Vehicles.

57. FCA directly markets, for its benefit, the Class Vehicles to consumers via extensive nationwide multimedia advertising campaigns on television, the internet, billboards, print, mailings, social media, and other mass media, which impart a universal and pervasive marketing message: safe and reliable family vehicles.

58. For example, in advertisements and marketing for the Ram 1500, FCA consistently referred to the Class Vehicles as “America’s Longest Lasting Pickups.”



59. Although FCA markets the Class Vehicles as durable and reliable trucks, they fail to meet that promise in the field. FCA omits that the Class Vehicles suffer from the Power Steering Defect. FCA has never disclosed the Power Steering Defect to Plaintiffs or other Class members.

60. Plaintiffs and the other Class members were exposed to FCA's pervasive and long-term marketing campaign touting the supposed quality and reliability of the Class Vehicles, and Plaintiffs and the other Class members made the justifiable decision to purchase or lease their Class Vehicles based on FCA's misleading marketing that omitted the Power Steering Defect.

F. FCA's Sale of Certified Pre-Owned Vehicles

61. All certified pre-owned FCA Class Vehicles are sold with warranties FCA issued at the time of sale. According to FCA, its certified pre-owned vehicles must pass a stringent certification process, including a comprehensive 125-point inspection and a thorough reconditioning process. FCA's Certified Pre-Owned Vehicle Warranty includes 3 months/3,000 miles of "maximum care" covering most of the vehicle's parts, and a 7-year/100,000 mile limited warranty covering parts used in the vehicle's powertrain. FCA's Certified Pre-Owned Warranty was not intended to benefit the initial dealer; it was intended to benefit the vehicle's ultimate consumer. Therefore, purchasers of the Class Vehicles, whether used or new, are third-party beneficiaries of these contractual warranties.

V. TOLLING OF STATUTES OF LIMITATIONS

A. Discovery Rule

62. FCA's knowing and active concealment and denial of the facts alleged herein act to toll any applicable statute(s) of limitations. Plaintiffs and other Class members could not have reasonably discovered the true, latent nature of the Power Steering Defect until shortly before commencing this class-action litigation.

63. Plaintiffs and Class members had no realistic ability to discover the presence of the Power Steering Defect in the Class Vehicles within the applicable statute of limitations and could not have discovered through the exercise of reasonable diligence that FCA was concealing the

Power Steering Defect in the Class Vehicles, or misrepresenting the safety, quality and reliability of the Class Vehicles.

B. Fraudulent Concealment

64. All applicable statutes of limitation have also been tolled by FCA's knowing, active and ongoing fraudulent concealment of the facts alleged herein. Even after Plaintiffs and other Class members contacted FCA and/or its authorized dealers to repair the Power Steering Defect, FCA and/or its dealers repeatedly and consistently told them the Class Vehicles were not defective.

65. As a result of FCA's active concealment, any and all applicable statutes of limitations otherwise applicable to the allegations herein have been tolled.

66. FCA has had, and continues to have, a duty to disclose the true character, quality, and nature of the Class Vehicles to Plaintiffs and the other Class members, including that the Class Vehicles require costly repairs, pose safety concerns, and have a diminished resale value.

67. Instead, FCA concealed the true character, quality, and nature of the Class Vehicles and knowingly made misrepresentations about the quality, reliability, characteristics, and performance of the Class Vehicles.

68. Plaintiffs and Class members have reasonably relied upon FCA's knowing and concealment of these facts.

69. Based on the foregoing, FCA is estopped from relying on any statutes of limitation in defense of this action.

C. Estoppel

70. FCA has, and continues to have, a duty to disclose to Plaintiffs and the other Class members the true character, quality, and nature of the Class Vehicles, including the facts that the Class Vehicles require costly repairs and pose safety concerns. As a result of FCA's active

concealment, any and all applicable statutes of limitations otherwise applicable to the allegations herein have been tolled.

VI. CLASS ACTION ALLEGATIONS

71. Plaintiffs bring this action on behalf of themselves, and on behalf of the following classes of consumers pursuant to Federal Rules of Civil Procedure, Rule 23(a), 23(b)(2), and/or 23(b)(3) defined as follows:

Nationwide Class:

All persons or entities who purchased or leased a 2013-2024 Ram 1500 vehicle in the United States from an authorized FCA dealership.

New Jersey Subclass:

All persons or entities who purchased or leased a 2013-2024 Ram 1500 in the State of New Jersey from an authorized FCA dealership.

72. Excluded from the Class are FCA, its affiliates, employees, officers and directors, persons or entities that purchased the Class Vehicles for resale, and the Judge(s) assigned to this case. Plaintiffs reserve the right to modify, change, or expand the Class definitions based on discovery and further investigation.

73. **Numerosity:** Upon information and belief, the Class is so numerous that joinder of all members is impracticable. While the exact number and identities of individual members of the Class are unknown at this time, such information being in FCA's sole possession and obtainable by Plaintiffs only through the discovery process, Plaintiffs believe, and on that basis alleges, that thousands of Class Vehicles have been sold and leased in states that are the subject of the Class.

74. **Existence and Predominance of Common Questions of Fact and Law:** Common questions of law and fact exist as to all members of the Class. These questions predominate over the questions affecting individual Class members. These common legal and factual questions include, but are not limited to, whether:

75. The Class Vehicles were sold with the Power Steering Defect;

- FCA knew about the Power Steering Defect but failed to disclose it and its consequence to Plaintiffs and the Class members;

76. A reasonable consumer would consider the Power Steering Defect, or its consequences, to be material;

- FCA should be required to disclose the Power Steering Defect and its consequences to future purchasers and lessees; and
- FCA's conduct violates the laws and statutes described herein.

77. **Typicality**: Plaintiffs' claim regarding the Power Steering Defect and FCA's failure to address it are typical of the claims of the Class because Plaintiffs purchased their vehicles with the same defect as other Class members. Furthermore, Plaintiffs and all members of the Class sustained monetary and economic injuries including, but not limited to, ascertainable losses arising out of FCA's failure to disclose the Power Steering Defect at the time of purchase. Plaintiffs advance these same claims and legal theories on behalf of themselves and all absent Class members.

78. **Adequacy**: Plaintiffs adequately represent the Class because their interests do not conflict with the interests of the Class they seek to represent, they have retained counsel competent and highly experienced in complex class action litigation, and they intend to prosecute this action vigorously. Plaintiffs and their counsel are well-suited to fairly and adequately protect Class interests.

79. **Superiority**: A class action is superior to all other available means of fairly and efficiently adjudicating the claims brought by Plaintiffs and the Class. The injury each individual Class member has suffered is small when compared to the burden and expense of individual

prosecuting the complex and extensive litigation FCA's conduct necessitates. It would be impossible for Class members on an individual basis to effectively redress the wrongs done to them. Even if Class members could afford such individual litigation, the courts cannot. Individualized litigation presents a potential for inconsistent or contradictory judgments. Individualized litigation increases the delay and expense to all parties and to the court system, particularly where the subject matter of the case may be technically complex. By contrast, the class action device presents far fewer management difficulties, and provides the benefits of single adjudication, an economy of scale, and comprehensive supervision by a single court. Upon information and belief, individual Class members can be readily identified and notified based on, *inter alia*, FCA's vehicle identification numbers, warranty claims, registration records, and database of complaints.

80. **Issues Class:** Alternatively, Plaintiffs seek certification pursuant to Federal Rule of Civil Procedure 23(c)(4) on behalf of the above-defined classes for some or all the issues identified in the commonality and predominance section, above, as well as other issues which may be later identified.

81. FCA has acted, and refused to act, on grounds generally applicable to the Class, thereby making appropriate final equitable relief with respect to the Class as a whole.

VII. CAUSES OF ACTION

A. Nationwide Claims

COUNT I

**VIOLATIONS OF THE MAGNUSSON-MOSS WARRANTY ACT
(15 U.S.C. § 2301, *et seq.*)
(Brought Plaintiffs on behalf of the Nationwide Class, or Alternatively, the State
Subclasses)**

82. Plaintiffs and the Class reassert and incorporate by reference all of the allegations of the preceding and succeeding paragraphs of as though fully set forth herein at length.

83. Plaintiffs and the other Class members are “consumers” within the meaning of 15 U.S.C. § 2310(3).

84. FCA is a “supplier” and “warrantor” within the meanings of sections 15 U.S.C. § 2301(4)–(5).

85. The Class Vehicles are “consumer products” within the meaning of 15 U.S.C. § 2301(1).

86. 15 U.S.C. §2310(d)(1) provides a cause of action for any consumer who is damaged by the failure of a warrantor to comply with any implied warranty.

87. As a matter of law, each Class Vehicle comes with an implied warranty of merchantability whereby FCA warrants each vehicle to be of merchantable quality such that it would pass without objection in the trade and is fit for the ordinary purposes for which it was to be used.

88. Defendant breached the implied warranty of merchantability, as the Class Vehicles are not fit for the ordinary purposes for which they are meant to be used, because their owners cannot reliably or safely drive their vehicles due to the Power Steering Defect.

89. Plaintiffs and the other Class members face the potential of their power steering systems failing to properly function while the Class Vehicles are in operation. The failure of the power steering system directly impairs the Class Vehicles’ drivability and reliability and makes them unsafe to operate.

90. The Class Vehicles would not pass without objection in the automotive trade and they are unfit for the ordinary purposes for which such vehicles are used because they create a

significant safety hazard. FCA tells Class Vehicle buyers that the vehicles have power steering, but when the defect manifests and the power steering fails, the operator must change how the vehicle is operated, often while beset with the element of surprise.

91. FCA's actions and omissions have deprived Plaintiffs and the Class members of the benefit of their bargain, have caused their Class Vehicles to be worth less than what Class members paid for.

COUNT II

FRAUDULENT CONCEALMENT/OMISSION

(Common Law)

(Brought by Plaintiffs on Behalf of the Nationwide Class, or Alternatively, the New Jersey Subclass)

92. Plaintiffs and the Class reassert and incorporate by reference all of the allegations of the preceding and succeeding paragraphs of as though fully set forth herein at length.

93. FCA concealed, omitted, and suppressed material facts concerning the performance and quality of the Class Vehicles—namely, the Power Steering Defect—and the quality of the FCA brand. Specifically, FCA knew about (or should have known about) the Power Steering Defect but failed to disclose it prior to, or at, the time it sold or leased Class Vehicles to consumers. FCA did so to boost sales and leases of Class Vehicles.

94. Plaintiffs and Class members had no way of knowing that FCA's representations were false and gravely misleading, or that FCA had omitted imperative details. Plaintiffs and Class members did not unravel FCA's deception on their own, nor could they have.

95. FCA had a duty to disclose the true performance of Class Vehicles, including the Power Steering Defect and its effects, because knowledge thereof and the details related thereto were known and/or accessible only to FCA; FCA had superior knowledge and access to the facts; and knew the facts were not known to, or reasonably discoverable, by Plaintiffs and the Class.

FCA also had a duty to disclose because the existence of the Power Steering Defect is material to purchase decision of reasonable consumer, as it constitutes an unreasonable safety defect and has a detrimental impact on the fundamental purpose and core function of the Class Vehicles.

96. On information and belief, FCA still has not made full and adequate disclosures, and continues to defraud consumers by concealing material information regarding the Power Steering Defect and the Class Vehicles' performance and quality.

97. Plaintiffs and the Class were unaware of these omitted material facts and would not have acted as they did if they had known of the concealed and/or suppressed facts, in that they would not have purchased or leased the Class Vehicles. The actions of Plaintiffs and Class members were justified. FCA was in exclusive control of the material facts and such facts were not known to the public, or Class members.

98. Plaintiffs and the Class relied upon FCA's representations and omissions regarding the quality of Class Vehicles and the Defect in deciding to purchase or lease Class Vehicles.

99. Because of the concealment and/or suppression of the facts, Plaintiffs and the Class sustained damage because they did not receive the value of the price paid for their Class Vehicles. Plaintiffs and Class members would have paid less for Class Vehicles had they known about the Power Steering Defect, or they would not have purchased or leased the Class Vehicles at all.

100. Accordingly, FCA is liable to Plaintiffs and Class members for damages in an amount to be proven at trial.

101. FCA's actions and omissions were done maliciously, oppressively, deliberately, with intent to defraud, and in reckless disregard of Plaintiffs' and the Class's rights and well-being, to enrich FCA. Accordingly, FCA's conduct warrants an assessment of punitive damages in an

amount sufficient to deter such conduct in the future, which amount is to be determined according to proof.

102. Furthermore, as the intended and expected result of its fraud and conscious wrongdoing, FCA has profited and benefited from Plaintiffs' and Class members' purchase of Class Vehicles with the defect. FCA has voluntarily accepted and retained these profits and benefits with full knowledge and awareness that, as a result of FCA's misconduct alleged herein, Plaintiffs and Class members were not receiving trucks of the quality, nature, fitness, or value that FCA represented, and that a reasonable consumer would expect.

103. FCA has been unjustly enriched by its fraudulent, deceptive, and otherwise unlawful conduct in connection with the sale and lease of Class Vehicles and by withholding benefits from Plaintiffs and Class members at the expense of these parties. Equity and good conscience militate against permitting FCA to retain these profits and benefits, and FCA should be required to make restitution of its ill-gotten gains resulting from the conduct alleged herein.

COUNT III

UNJUST ENRICHMENT

(Common Law)

(Brought by Plaintiffs on Behalf of the Nationwide Class, or Alternatively, the New Jersey Subclasses)

104. Plaintiffs and the Class reassert and incorporate the allegations of the preceding and succeeding paragraphs of this Complaint as though fully alleged herein at length.

105. Plaintiffs bring this claim individually and on behalf of themselves and the Nationwide Class, or, in the alternative, on behalf of the State-specific Subclasses.

106. FCA, as the manufacturer, distributor, and/or seller represented that the Class Vehicles were safe for consumers in their normal operation. But the Class Vehicles are not safe because of the Power Steering Defect, which can occur at all speeds during the vehicle's normal

operation. Without offering a suitable repair, FCA unjustly enriches itself at its consumers' expense and safety.

107. FCA has been unjustly enriched in retaining revenues derived from Plaintiffs and the Class members' purchase of the Class Vehicles. FCA's misrepresentations caused Plaintiffs and the Class members harm and unjustly enriched FCA because Plaintiffs and Class members would not have purchased the Class Vehicles, or paid the price that they did, had FCA disclosed the material facts to consumers.

108. FCA has been unjustly enriched because the Power Steering Defect tends to manifest later in the useful life of the vehicle, after which Class Vehicle owners must pay out of pocket expenses to repair the defect.

109. Because FCA has unjustly retained the non-gratuitous benefits conferred upon it by Plaintiffs and the Class, FCA must pay restitution to Plaintiffs and the Class.

B. New Jersey Claims

COUNT IV

**VIOLATION OF NEW JERSEY CONSUMER FRAUD ACT
(N.J. Stat. Ann. § 56:8-1, et seq.)
(Brought by Plaintiffs on Behalf of the New Jersey Subclass)**

110. Plaintiffs and the New Jersey Subclass incorporate by reference each preceding and succeeding paragraph as though fully set forth at length herein.

111. Plaintiffs bring this cause of action on behalf of themselves and the New Jersey Subclass.

112. Plaintiffs and the New Jersey Subclass members, and FCA are persons under the New Jersey Consumer Fraud Act, N.J. Stat. Ann. § 56:8-1(d).

113. FCA engaged in “sales” of “merchandise” within the meaning of New Jersey Statutes § 56:8-1(c), (e). FCA’s actions as set forth herein occurred in the conduct of trade or commerce.

114. The New Jersey Consumer Fraud Act (“NJCFA”) makes unlawful “[t]he act, use or employment by any person of any unconscionable commercial practice, deception, fraud, false pretense, false promise, misrepresentation, or the knowing concealment, suppression or omission of any material fact with the intent that others rely upon such concealment, suppression or omission, in connection with the sale or advertisement of any merchandise or real estate, or with the subsequent performance of such person as aforesaid, whether or not any person has in fact been misled, deceived or damaged thereby” N.J. Stat. Ann. § 56:8-2.

115. FCA engaged in deceptive trade practices in violation of the NJCFA, including (1) knowingly making a false representation as to the characteristics, uses, and benefits of the Class Vehicles that had the capacity or tendency to deceive Plaintiffs and the New Jersey Subclass members; (2) representing that the Class Vehicles are of a particular standard, quality, and grade even though FCA knew or should have known they are not; (3) advertising the Class Vehicles with the intent not to sell them as advertised; and (4) failing to disclose material information concerning the Class Vehicles that was known to FCA at the time of advertisement or sale with the intent to induce Plaintiffs and the New Jersey Subclass members to purchase or lease the Defective Vehicles.

116. FCA knew that the Class Vehicles were defectively designed or manufactured, would fail without warning, and were not suitable for their intended use. FCA, nevertheless, failed to warn Plaintiffs or the New Jersey Subclass members about these inherent dangers despite having a duty to do so.

117. FCA had the duty to Plaintiffs and the New Jersey Subclass members to disclose the Power Steering Defect and the defective nature of the Class Vehicles because:

- a. FCA was in a superior position to know the true state of facts about the Power Steering Defect and associated repair costs in the Class Vehicles;
- b. Plaintiffs and the New Jersey Subclass members could not reasonably have been expected to learn or discover that the Class Vehicles had dangerous defects until manifestation of the defects;
- c. FCA knew that Plaintiffs and the New Jersey Subclass members could not reasonably have been expected to learn about or discover the Power Steering Defect and its associated repair costs; and
- d. FCA actively concealed the Power Steering Defect, its causes, and resulting effects, by asserting to Plaintiffs and New Jersey Subclass members that their electric power steering systems failed for reasons other than the Power Steering Defect.

118. FCA's practices significantly affected the public as consumers of the Class Vehicles, which pose an unreasonable risk of death or serious bodily injury to Plaintiffs and the New Jersey Subclass members, passengers, other motorists, pedestrians, and the public at large, because they are susceptible to loss of power and fire.

119. Whether or not a vehicle's EPS Unit contains a defect substantially certain to manifest within the Class Vehicles' useful lifetime is a fact a reasonable consumer would consider important in selecting a vehicle to purchase or lease. When Plaintiffs and the New Jersey Subclass members bought a Class Vehicle for personal, family, or household purposes, they reasonably expected the vehicle would have non-defective power steering systems.

120. FCA's deceptive practices were likely to and did in fact deceive reasonable consumers, including Plaintiffs and the New Jersey Subclass members, about the true safety and reliability of the Class Vehicles.

121. FCA's unlawful practices have caused substantial harm to consumers.

122. The Power Steering Defect alleged herein was material to Plaintiffs and to the New Jersey Subclass members. Had Plaintiffs and the New Jersey Subclass members known that the Class Vehicles had this material safety defect, they would not have purchased the Class Vehicles or would not have paid as much for them.

123. Plaintiffs and the New Jersey Subclass members suffered ascertainable loss of money or property caused by FCA's unlawful practices. Plaintiffs and the New Jersey Subclass members overpaid for their vehicles and did not receive the benefit of their bargain. The value of the Class Vehicles has diminished now that the safety issues have come to light, and Plaintiffs and the New Jersey Subclass members now own or lease the Class Vehicles, which are unsafe.

124. Plaintiffs and the New Jersey Subclass members are entitled to recover legal and/or equitable relief, treble damages, and reasonable attorneys' fees pursuant to New Jersey Statutes Annotated § 56:8-19.

125. Pursuant to New Jersey Statutes Annotated § 56:8-20, Plaintiffs will mail a copy of the complaint to the Attorney General of New Jersey within ten (10) days of filing.

COUNT V

BREACH OF IMPLIED WARRANTY OF MERCHANTABILITY (N.J. Stat. Ann. § 12A:2-314) (Brought by Plaintiffs on Behalf of the New Jersey Subclass)

126. Plaintiffs and the New Jersey Subclass members incorporate by reference each preceding and succeeding paragraph as though fully set forth at length herein.

127. FCA was at all relevant times the manufacturer, distributor, warrantor, and/or seller of the Class Vehicles. FCA knew or had reason to know of the specific use for which the Class Vehicles were purchased.

128. FCA provided Plaintiffs and the New Jersey Subclass members with an implied warranty that the Class Vehicles and any parts thereof are merchantable and fit for the ordinary purposes for which they were sold. However, the Class Vehicles are not fit for their ordinary purpose of providing reasonably reliable and safe transportation at the time of sale or thereafter because, *inter alia*, the Class Vehicles suffered from the Power Steering Defect at the time of sale. Therefore, the Class Vehicles are not fit for their particular purpose of providing safe and reliable transportation.

129. FCA implied that the Class Vehicles were of merchantable quality and fit for such use. This implied warranty included, among other things: (i) a warranty that the Class Vehicles and their power steering systems manufactured, supplied, distributed, and/or sold by FCA were safe and reliable for the purpose for which they were installed; and (ii) a warranty that the Class Vehicles would be fit for their intended use.

130. Contrary to the applicable implied warranties, the Class Vehicles at the time of sale and thereafter were not fit for their ordinary and intended purpose of providing Plaintiffs and the New Jersey Subclass members with reliable, durable, and safe transportation. Instead, the Class Vehicles suffer from a defective design(s) and/or manufacturing defect(s).

131. FCA's actions, as complained of herein, breached the implied warranty that the Class Vehicles were of merchantable quality and fit for such use.

132. FCA had actual knowledge of, and received reasonable notice regarding, the Power Steering Defect at issue in this litigation and, notwithstanding such notice, failed and refused to offer an effective remedy.

133. As a direct and proximate result of FCA's breach of warranties, Plaintiffs and the New Jersey Subclass members suffered economic damage, including loss attributable to the

overpayment of their Class Vehicles, loss of use of their Class Vehicles and other tangible property, as well as the monies spent or to be spent to repair and/or replace the power steering rack and pinion in each of their vehicles.

VIII. PRAYER FOR RELIEF

WHEREFORE, Plaintiffs, on behalf of themselves and the members of the Class, respectfully requests this Court:

- a. determine that the claims alleged herein may be maintained as a class action under Rule 23 of the Federal Rules of Civil Procedure, and issue an order certifying the Class as defined above;
- b. appoint Plaintiffs as the representatives of the Class and their counsel as Class counsel;
- c. award all actual, general, special, incidental, statutory, punitive, and consequential damages and restitution to which Plaintiffs and members of the Class are entitled;
- d. award pre-judgment and post-judgment interest on any monetary relief;
- e. grant appropriate injunctive and/or declaratory relief, including, without limitation, an order that requires FCA to repair, recall, and/or replace the Class vehicles and to extend the applicable warranties to a reasonable period of time, or, at a minimum, to provide Plaintiffs and Class members with appropriate curative notice regarding the existence and cause of the Power Steering Defect;
- f. award reasonable attorneys' fees and costs; and
- g. grant such further relief that this Court deems appropriate.

IX. DEMAND FOR JURY TRIAL

Plaintiffs hereby demand a jury trial for all claims so triable.

Dated: August 30, 2024

Respectfully Submitted,

By: /s/ Michele M. Vercoski
Michele M. Vercoski, Bar No.: 031012004
**MCCUNE LAW GROUP,
MCCUNE WRIGHT AREVALO VERCOSKI
KUSEL WECK BRANDT, APC**
18565 Jamboree Rd. Suite 550
Irvine, CA 92612
Telephone: (714) 909-2326
mmv@mccunewright.com

David C. Wright (*Pro Hac Vice Forthcoming*)
Mark I. Richards (*Pro Hac Vice Forthcoming*)
Jordan I. Wispell (*Pro Hac Vice Forthcoming*)
**MCCUNE LAW GROUP,
MCCUNE WRIGHT AREVALO VERCOSKI
KUSEL WECK BRANDT, APC**
3281 East Guasti Rd., Suite 100
Ontario, CA 91761
Telephone: (909) 557-1250
Facsimile: (909) 557-1275
dcw@mccunewright.com
mir@mccunewright.com
jiw@mccunewright.com

Attorneys for Plaintiffs and the Putative Class

ClassAction.org

This complaint is part of ClassAction.org's searchable class action lawsuit database and can be found in this post: [Class Action Claims 2013-2024 Ram 1500 Pickups Plagued By Power Steering Defect](#)
